

(19) World Intellectual Property
Organization
International Bureau



(43) International Publication Date
27 January 2005 (27.01.2005)

PCT

(10) International Publication Number
WO 2005/007796 A2

- (51) International Patent Classification⁷: **C12M** (IL). **DEUTSCH, Assaf** [IL/IL]; 12 Moshav Tzofaria, 60 932 Moshav Tzofaria (IL).
- (21) International Application Number: PCT/IL2004/000661 (74) Agent: **G.E. EHRLICH (1995) LTD.**; 11 Menachem Begin Street, 52 521 Ramat Gan (IL).
- (22) International Filing Date: 20 July 2004 (20.07.2004) (81) Designated States (unless otherwise indicated, for every kind of national protection available): AE, AG, AL, AM, AI, AU, AZ, BA, BB, BG, BR, BW, BY, BZ, CA, CH, CN, CO, CR, CU, CZ, DE, DK, DM, DZ, EC, EE, EG, ES, FI, GB, GD, GE, GH, GM, HR, HU, ID, IL, IN, IS, JP, KE, KG, KP, KR, KZ, LC, LK, LR, LS, LT, LU, LV, MA, MD, MG, MK, MN, MW, MX, MZ, NA, NI, NO, NZ, OM, PG, PH, PL, PT, RO, RU, SC, SD, SE, SG, SK, SL, SY, TJ, TM, TN, TR, TT, TZ, UA, UG, US, UZ, VC, VN, YU, ZA, ZM, ZW.
- (25) Filing Language: English
- (26) Publication Language: English
- (30) Priority Data:
60/488,408 21 July 2003 (21.07.2003) US
60/488,409 21 July 2003 (21.07.2003) US
60/517,073 5 November 2003 (05.11.2003) US
60/517,084 5 November 2003 (05.11.2003) US
60/544,356 17 February 2004 (17.02.2004) US
60/544,357 17 February 2004 (17.02.2004) US
PCT/IL04/000571 27 June 2004 (27.06.2004) IL
- (71) Applicant (for all designated States except US): **MOLECULAR CYTOMICS LTD.** [CY/CY]; P.O. Box 21255, 1505 Nicosia (CY).
- (72) Inventors; and
- (75) Inventors/Applicants (for US only): **DEUTSCH, Mordechai** [IL/IL]; 73 Moshav Olesh, 42 855 Doar Na Lev-HaSharon (IL). **HERZBERG, Max** [IL/IL]; Moshav Sitria, P. O. Box 7, 76 834 Emeq Soreq (IL). **TIROSH, Reuven** [IL/IL]; 20 Ben Gurion Street, 44257 Kfar Saba
- Published:**
— without international search report and to be republished upon receipt of that report
- For two-letter codes and other abbreviations, refer to the "Guidance Notes on Codes and Abbreviations" appearing at the beginning of each regular issue of the PCT Gazette.



WO 2005/007796 A2

(54) Title: IMPROVED MULTIWELL PLATE

(57) Abstract: A multiwell plate having a plurality of picowells on the bottom of the wells of the plate as well as methods of producing the multiwell plate are provided. Provided is also a method of handling living cells by providing an ordered array of living cells immobilized in a non-fluid matrix, contacting the living cells with a stimulus; and detecting a response to the stimulus. The present invention is also of a method of producing an ordered array of living cells.

IMPROVED MULTIWELL PLATE

FIELD AND BACKGROUND OF THE INVENTION

5 The present invention relates to the field of cellular biology and more particularly, to an improved device and method for the study of cells. Specifically, the present invention is of an improved multiwell plate and methods for making the same that allows the use of automatised sample handling methods for the study of single living cells. Further, the present invention is of a device substantially being an ordered array of living cells.

10 Combinatorial methods in chemistry, cellular biology and biochemistry are essential for the near simultaneous preparation of multitudes of active entities such as molecules. Once such a multitude of molecules is prepared, it is necessary to study the effect of each one of the active entities on a living organism.

15 The study of the effects of stimuli, such as exposure to active entities, on living organisms is preferably initially performed on living cells. Since, cell-functions include many interrelated pathways, cycles and chemical reactions, the study of an aggregate of cells, whether a homogenous or a heterogeneous aggregate, does not provide sufficiently detailed or interpretable results: rather a comprehensive study of the biological activity of an active entity may be advantageously performed by examining
20 the effect of the active entity on a single isolated living cells. Thus, the use of single-cell assays is one of the most important tools for understanding biological systems and the influence thereupon of various stimuli such as exposure to active entities.

25 The combinatorial preparation of a multitudes of active entities coupled with the necessity of studying the effect of each one of the active entities on living organisms using a single-cell assay, requires the development of high-throughput single live cell assays.

In the art, various different methods for studying living cells are known.

30 Multiwell plates having 6, 12, 48, 96, 384 or even 1536 wells on a standard *ca.* 8.5 cm by *ca.* 12.5 cm footprint are well known in the art. Such multiwell plates are provided with an $2n$ by $3n$ array of rectangular packed wells, n being an integer. The diameter of the wells of a plate depends on the number of wells and is generally greater than about 250 microns (for a 1536 well plate). The volume of the wells depends on the

- 2 -

number of wells and the depth thereof but generally is greater than 5×10^{-6} liter (for a 1536 well plate).

Multiwell plates are commercially available from many different suppliers. Multiwell plates made from many different materials are available, including but not
5 limited to glass, plastics, quartz and silicon. Multiwell plates having wells where the inside surface is coated with various materials, such as active entities, are known.

The standardization of the formats of multiwell plates is a great advantage for researchers as the standardization allows the production of standardized products including robotic handling devices, automated sample handlers, sample dispensers, plate
10 readers, observation devices, plate washers, software and such accessories as multifilters.

Although exceptionally useful for the study of large groups of cells, multiwell plates are not suitable for the study of individual cells or even small groups of cells due to the large, relative to the cellular scale, size of the wells. Cells held in such wells
15 either float about a solution or adhere to a well surface. When cells float about in a well, specific individual cells are not easily found for observation. When cells adhere to a well surface, the cells adhere to any location in the well, including anywhere on the bottom of the well and on the walls of the well. Such variability in location makes high-throughput imaging (for example for morphological studies) challenging as acquiring an
20 individual cell and focusing thereon is extremely difficult. Such variability in location also makes high-throughput signal processing (for example, detection of light emitted by a single cell through fluorescent processes) challenging as light must be gathered from the entire area of the well, decreasing the signal to noise ratio. Further, a cell held in a well of a multiwell plate well can be physically or chemically manipulated (for
25 example, isolation or movement of a single selected cell or single type of cell, changing media or introducing drugs) only with difficulty. Further, the density of cells held singly in the wells of a multiwell plate is very low (about 1536 cells in 65 cm^2 , or 24 cells cm^{-2}) Thus, multiwell plates are in general only suitable for the study of homogenous or heterogenous aggregates of cells as a group.

30 An additional disadvantage of multiwell plates is during the study of cells undergoing apoptosis. One method of studying cells is by exposing cells in a monolayer of cells adhered to the bottom of the well of a multiwell plate to a stimulus. As is known

to one skilled in the art, one of the most important processes that a cell potentially undergoes is apoptosis and it is highly desirable to observe a cell throughout the apoptosis process. However, once a cell begins the apoptosis process, the adhesion of the cell to the bottom of the well is no longer sufficient: the cell detaches from the
5 bottom and is carried away by incidental fluid currents in the well. The cell is no longer observable and its identity lost.

In the art, a number of method and devices have been developed for the study of individual cells or a small number of cells as a group. Many such methods are based on using picowell-bearing devices. A picowell-bearing device is a device for the study of
10 cells that has at least one picowell-bearing component for study of cells. A picowell-bearing component is a component having at least one, but generally a plurality of picowells, each picowell configured to hold at least one cell. The term "picowell" is general and includes such features as dimples, depressions, tubes and enclosures. Since cells range in size from about 1 microns to about 100 (or even more) microns diameter
15 there is no single picowell size that is appropriate for holding a single cell of any type. That said, the dimensions of the typical individual picowell in the picowell-bearing components known in the art have dimensions of between about 1 microns up to about 200 microns, depending on the exact implementation. For example, a device designed for the study of single isolated 20 micron cells typically has picowells of dimensions of
20 about 20 microns. In other cases, larger picowells are used to study the interactions of a few cells held together in one picowell. For example, a 200 micron picowell is recognized as being useful for the study of the interactions of two or three cells, see PCT patent application IL01/00992 published as WO 03/035824.

One feature that increases the utility of a picowell-bearing device is that each
25 individual picowell is individually addressable. By individual addressability is meant that each picowell can be registered, found or studied without continuous observation. For example, while cells are held in picowells of a picowell-bearing component, each cell is characterized and the respective picowell where each cell is held is noted. When desired, the observation component of the picowell-bearing device is directed to the
30 location of the picowell where a specific cell is held. One method of implementing individual addressability is by the use of fiducial points or other features (such as signs or labels), generally on the picowell-bearing component. Another method of

implementing individual addressability is by arranging the picowells in a picowell-array and finding a specific desired picowell by counting. Another method of implementing individual addressability is by providing a dedicated observation component for each picowell.

5 In the art, the picowell-bearing component of picowell-bearing devices is often a chip, a plate or other substantially planar component. Herein such a component is termed a "carrier". In the art, there also exist non-carrier picowell-bearing components of picowell-bearing devices, for example, bundles of fibers or bundles of tubes.

 Mrksich and Whitesides, *Ann. Rev. Biophys. Biomol. Struct.* **1996**, *25*, 55-78;
10 Craighead *et al.*, *J. Vac. Sci. Technol.* **1982**, *20*, 316; Singhvi *et al.*, *Science* **1994**, *264*,
696-698; Aplin and Hughes, *Analyt. Biochem.* **1981**, *113*, 144-148 and U.S. Patent
5,324,591 all teach of devices including arrays of spots of cell-attracting or cell-binding
entities on a plate. In such devices, the spots serve as picowells, binding to cells through
a variety of chemical bonds. In such devices, the plate is the picowell-bearing
15 component of the device. Due to the size of the spots, each such picowell generally
holds more than one cell. To reduce interaction between cells held at different
picowells, the spots must be spaced relatively far apart, reducing loading as expressed in
terms of picowells per unit area. Even with generous spacing, in such picowell-bearing
components held cells are not entirely isolated from mutual interaction, nor can cells be
20 subject to individual manipulation. The fact that the cells are not free-floating but are
bound to the plate through some interaction necessarily compromises the results of
experiments performed.

 In U.S. Patent 6,103,479, the picowell-bearing component is a transparent
carrier provided with a non-uniform array of picowells, each well functionalized with
25 chemical entities that bind to cells specifically or non-specifically. Each picowell is of
approximately 200 to 1000 micron diameter and is configured to hold a plurality of
cells. The inter picowell areas are hydrophobic so as not to attract cells. In addition to
the carrier, a device of U.S. Patent 6,103,479 is provided with a glass, plastic or silicon
chamber-bearing plate in which individually addressable microfluidic channels are
30 etched that mates with the carrier. When brought together, the carrier and chamber-
bearing plate constitute a cassette in which each cell is bound to the carrier and isolated
in a chamber provided with an individual fluid delivery system. Reagents are provided

- 5 -

through the fluid delivery system and observed by the detection of fluorescence. In order to provide space for the walls of the chambers, the inter picowell areas of the carrier are relatively large, reducing loading as expressed in terms of picowells per unit area. Subsequent to study, the cassette is separated into the two parts and the micro-patterned array of cells processed further. In some embodiments, the chamber-bearing plate is made of polytetrafluoroethylene, polydimethylsiloxane or an elastomer. As held cells do not make contact with the chamber-bearing plate it is not clear what advantages are to be had when providing a chamber-bearing plate of such esoteric materials.

In U.S. Patent 4,729,949, a device is taught for trapping individual cells in a picowell-bearing carrier, the carrier being substantially a plate having a plurality of picowells that are individually-addressable tapered apertures of a size to hold individual cells. Suction applied from the bottom surface of the plate where the picowells are narrow creates a force that draws cells suspended in a fluid above the carrier into the wide end of the picowells on the surface of the carrier to be held therein. Using the teachings of U.S. Patent 4,729,949 a specific group of cells (having dimensions similar to that of the wide end of the picowells) can be selected from amongst a group of cells and held in the carrier. Although the cells are subjected to common stimuli, the fact that the picowells are individually addressable allows the effect of a stimulus on an individual cell to be observed. A carrier of U.S. Patent 4,729,949, is generally made of metal such as nickel and prepared using standard photoresist and electroplating techniques. In a carrier of U.S. Patent 4,729,949, the inter picowell areas of the carrier are relatively large, leading to a low loading as expressed in terms of picowells per unit area. Further, the suction required to hold cells in picowells of a carrier of U.S. Patent 4,729,949 deforms held cells and makes a significant portion of the cell membranes unavailable for contact, both factors that potentially compromise experimental results. Study of cells with non-fluorescence based methods generally gives poor results due to reflections of light from the carrier.

In PCT patent application US99/04473 published as WO 99/45357 is taught a picowell-bearing device produced by etching the ends of a bundle of optical fibers (apparently of glass) while leaving the cladding intact to form a picowell-bearing component that is a bundle of tubes. The size of the hexagonal picowells is demonstrated to be as small as 7 micron wide, 5 micron deep and having a volume of

- 6 -

1.45 x 10⁻¹³ liter. The inter picowell area is quite large due to the thickness of the cladding of the optical fibers. Cells held in each picowell are independently observable through a respective optical fiber. In some embodiments, the inside surface of the picowells is coated with a film of materials such as collagen, fibronectin, polylysine, polyethylene glycol, polystyrene, fluorophores, chromophores, dyes or a metal. Loading the picowell-bearing component of PCT patent application US99/04473 includes dipping the optical fiber bundle in a cell suspension so that cells adhere to the picowells. There are a number of disadvantages to the teachings of PCT patent application US99/04473. The fact that the cells are studied only subsequent to adhesion to the picowells necessarily influences the results of experiments performed. Since cell proliferation generally begins soon after adhesion, it is never clear if a signal detected results from a single cell or a plurality of cells. It is not clear where exactly in a picowell a cell is held and therefore what percentage of light emitted from a cell travels to a detector. The fact that emitted light travels through an optical fiber leads to loss of time-dependent and phase information.

In unpublished copending PCT patent application IL04/00192 of the Applicant filed 27 June 2004 is taught a picowell-bearing device produced by bundling together glass capillaries, each glass capillary attached to an independent fluid flow generator such as a pump. A cell held in a first picowell is transferred to a second picowell by the simultaneous application of an outwards flow from the first picowell and an inwards flow into the second picowell.

A preferred device for the study of cells is described in PCT patent application IL01/00992 published as WO 03/035824. The device 10, depicted in Figure 1, is provided with a transparent carrier 12 as a picowell-bearing component. Carrier 12 is substantially a sheet of transparent material (such as glass or polystyrene) on the surface of which features such as inlet connectors 14, fluid channels 16, picowells (in Figure 1 a well-array 18), a fluid reservoir 20 and an outlet connector 22. Carrier 12 is immovably held in a holder 24 having a cutout window of a size and shape to accept carrier 12. Other components of device 10 not depicted include flow generators, observation components, external tubing and the like. When a cover slip (not depicted) is placed or integrally formed with carrier 12, fluid channels 16, picowell-array 18 and reservoir 20 are sealed forming channels that allow transport of fluids and reagents to cells held in

picowell-array 18. The picowells are configured to hold a predetermined number of cells (one or more) of a certain size and are preferably individually addressable both for examination and manipulation.

Figure 2 is a reproduction of a photograph of a different carrier 26 held in a holder 24. A first syringe 28 as an inlet flow generator is in communication with an inlet connector 14 by a capillary tube 30. Inlet connector 14 is in communication with picowell-array 18 through a fluid passage 16. Picowell-array 18 is in communication with outlet connector 22 through a fluid passage 16. A second syringe 32 as an outlet flow generator is in communication with outlet connector 22 through capillary tube 34.

PCT patent application IL01/00992 also teaches methods of physically manipulating cells held in a picowell-bearing device using, for example, individually addressable microelectrodes (found in the picowells or in the cover slip) or optical tweezers. Typical physical manipulations include moving cells into or out of picowells. One useful method that is implemented using a device of PCT patent application IL01/00992 is that cells, each held alone in a respective picowell, are examined (either in the presence or absence of reagents) and based on the results of the examination, cells with a certain characteristic are selected to remain in a respective picowell while cells without the certain characteristic are removed from a respective picowell and ejected by the application of a flow in parallel to the surface of the carrier, generated by a flow generator.

An additional feature of the teachings of PCT patent application IL01/00992 is that, in some embodiments, the picowells are juxtaposed, that is, the area occupied by a picowell-array is substantially entirely made up of picowells with little or no inter picowell area, see Figure 3. Figure 3 is a reproduction of a photograph of part of a picowell-array 18 from the top of a carrier 12 of PCT patent application IL01/00992. In Figure 3 is seen a plurality of hexagonal picowells 36, some populated with living cells 38. It is seen that the inter picowell areas 40 make up only a minor percentage of the total area of picowell-array 18. This feature allows near tissue-density packing of cells, especially in single-cell picowell configurations. For example, a typical device of PCT patent application IL01/00992 having a 2 mm by 2 mm picowell-array of hexagonally-packed juxtaposed picowells of 10 micron diameter and no inter picowell area includes about 61600 picowells. This feature also allows simple picowell loading: a fluid

- 8 -

containing suspended cells is introduced in the volume above the picowells. Since there is little inter picowell area, cells settle in the picowells.

Despite the utility of the device taught in PCT patent applications IL01/00992, the use of the device is too labor intensive for certain high-throughput implementations. Amongst other reasons the large amount of labor is required because there exist no
5 commercially available robotic systems optimized for use with the devices.

It would be highly advantageous to have a device for the study of cells not having at least some of the disadvantages of the prior art.

10 SUMMARY OF THE INVENTION

The present invention successfully addresses at least some of the shortcomings of the prior art by providing an improved multiwell plate and a new device, a method for producing the improved multiwell plate and the new device and new methods for handling living cells.

15 According to the teachings of the present invention there is provided a multiwell plate comprising a plurality of wells wherein at the bottom surface of at least one well of the plurality of wells is a plurality of picowells. Preferably, a plate of the present invention has a footprint of a standard multiwell plate. Preferably, the plurality of wells of a plate of the present invention comprises $6n$ wells arranged in a $2n$ by $3n$ array,
20 where n is an integer greater than 0, the wells preferably being arranged in rectangular packing. Preferred pluralities of wells are the commonly known pluralities of well such as 6, 24, 96, 384 and 1536 wells. Most preferred are plates of 96 wells and 384 wells as these formats are most popular and have many available accessories including fluid-handling accessories such as fluid-handling robots.

25 In an embodiment of the present invention, the plurality of picowells comprises individually addressable picowells. In an embodiment of the present invention, the bottoms of all picowells in a given well of a plate of the present invention are substantially coplanar. In an embodiment of the present invention, the bottoms of all picowells of a plate of the present invention are substantially coplanar.

30 In an embodiment of the present invention, the picowells of a plurality of picowells in a given well are juxtaposed. By juxtaposed is meant that in an area where picowells are found, most of the area is picowell area and little of the area is inter

picowell area. According to a feature of the present invention, by juxtaposed is meant that the inter picowell area between two picowells is less than or equal to 0.35, 0.25, 0.15, 0.10 or even 0.06 of the sum of the areas of the two picowells. In certain embodiments of the present invention it is preferred that the inter picowell area be
5 substantially zero, that is that the rims of picowells are substantially knife-edged.

The dimensions of picowells of a multiwell plate of the present invention, depending on the specific embodiment, are less than about 200 microns, less than about 100 microns, less than about 50 microns, less than about 25 microns or even less than about 10 microns. In an embodiment of the present invention, picowells are configured
10 to hold no more than one living cell of a certain size at any one time. In an embodiment of the present invention, picowells are configured to hold no more than a predetermined number of living cells of a certain size at any one time.

In an embodiment of the present invention, the picowells are enclosures of dimensions such that substantially at least one entire cell of a certain size is containable
15 within such an enclosure, each enclosure having an opening at the surface of the carrier, the opening defined by a first cross section of a size allowing passage of a cell of the certain size. Depending on the embodiment, the volume of such an enclosure is typically less than about 1×10^{-11} liter, less than about 1×10^{-12} liter, less than about 1×10^{-13} liter, less than about 1×10^{-14} liter or even less than about 1×10^{-15} liter.
20 Depending on the embodiment, the area of the first cross section of such an enclosure is typically less than about 40000 micron^2 , less than about 10000 micron^2 , less than about 2500 micron^2 , less than about 625 micron^2 or even less than about 100 micron^2 . In an embodiment of the present invention, picowells' enclosures are configured to hold no more than one living cell of a certain size at any one time. In an embodiment of the
25 present invention, picowells enclosures are configured to hold no more than a predetermined number of living cells of a certain size at any one time.

In an embodiment of the present invention, the plurality of picowells comprises picowells, wherein all picowells of the plate are substantially identical in size.

In another embodiment of the present invention, a first well of a plate of the
30 present invention includes a first plurality of picowells and a second well of a plate includes a second plurality of picowells, wherein the first plurality of picowells and the second plurality of picowells are substantially different. For example, in an embodiment

- 10 -

of the present invention the size of the picowells of the first plurality is substantially different from the size of picowells of the second plurality of picowells.

A multiwell plate of the present invention is made of any suitable material. Suitable materials include but are not limited to ceramics, elastomers, epoxies, glasses, 5 glass-ceramics, metals, plastics, polycarbonates, polydimethylsiloxane, polyurethane, polyethylenterephthalate glycol, polymers, polymethyl methacrylate, polystyrene, polyvinyl chloride, rubber, silicon, silicon oxide and silicon rubber.

In an embodiment of the present invention, the bottom surface of the wells is made of any suitable material. Suitable materials include but are not limited to ceramics, 10 elastomers, epoxies, glasses, glass-ceramics, metals, plastics, polycarbonates, polydimethylsiloxane, polyethylenterephthalate glycol, polymers, polymethyl methacrylate, polystyrene, polyurethane, polyvinyl chloride, rubber, silicon, silicon oxide and silicon rubber.

In embodiments of the present invention, an entire plate of the present invention 15 and all components thereof are made of one material. In other embodiments, a plate of the present invention is made up of a number of different materials, for example, as a plurality of layers or as a coated structure.

In an embodiment of the present invention, the walls of wells of the plurality of wells are integrally formed with the bottom surface of the wells.

20 In other embodiments, a plate of the present invention comprises at least one distinct well-wall component attached to the bottom surface. Such a distinct well-wall component is made of any suitable material. Suitable materials include but are not limited to ceramics, elastomers, epoxies, glasses, glass-ceramics, metals, plastics, polycarbonates, polydimethylsiloxane, polyethylenterephthalate glycol, polymers, 25 polyurethane, polymethyl methacrylate, polystyrene, polyvinyl chloride, rubber, silicon, silicon oxide and silicon rubber.

In an embodiment of the present invention, a plurality of picowells are integrally formed with the bottom surface.

30 In an embodiment of the present invention, a plate of the present invention comprises at least one distinct picowell-bearing component bearing a plurality of picowells, the component attached to the bottom surface of a respective well or simply resting within a respective well.

- 11 -

A suitable distinct picowell-bearing component is a carrier comprising a plurality of picowells disposed on a surface, such as a carrier described in PCT patent application IL01/00992 or in unpublished copending PCT patent application IL04/00571 of the Applicant filed 27 June 2004 (*vide infra*). Picowell-bearing components are made of any suitable material, including reversibly deformable materials and irreversibly deformable materials. Suitable materials include but are not limited to gels, hydrogels, waxes, hydrocarbon waxes, crystalline waxes, paraffins, ceramics, elastomers, epoxies, glasses, glass-ceramics, metals, plastics, polycarbonates, polydimethylsiloxane, polyethyleneterephthalate glycol, polymers, polymethyl methacrylate, polystyrene, polyurethane, polyvinyl chloride, rubber, silicon, silicon oxide and silicon rubber.

In an embodiment of the multiwell plate of the present invention, the picowell-bearing component comprises a gel, preferably a transparent gel, preferably a hydrogel.

Gels suitable for use in making a picowell-bearing component of a plate of the present invention include but are not limited to agar gels, agarose gels, gelatins, low melting temperature agarose gels, alginate gels, room-temperature Ca^{2+} -induced alginate gels and polysaccharide gels. Depending on the embodiment, a suitable gel has a water content of greater than about 80% by weight, greater than about 92% by weight, greater than about 95% by weight, greater than about 97% by weight and even greater than about 98% by weight. In an embodiment of the present invention, the gel includes an active entity. Suitable active entities include, but are not limited to antibodies, antigens, biological materials, chemical materials, chromatogenic compounds, drugs, enzymes, fluorescent probes, immunogenes, indicators, ligands, nucleic acids, nutrients, peptides, physiological media, proteins, receptors, selective toxins and toxins.

In an embodiment of the present invention, picowells have a bottom surface made of a first material and borders, such as the borders delineating the picowells, made of a second material, the second material being substantially different from the first material. In an embodiment of the present invention the first material is substantially the material from which the bottom of the well is made, for example when the bottom surface of the picowell is substantially the bottom surface of the well. In an embodiment of the present invention, the second material is a fixed photoresist material.

In an embodiment of the plate of the present invention, the plurality of picowells comprises picowells having an inside surface configured to delay proliferation of cells held therein, for example, by delaying adhesion of living cells thereto. In an embodiment of the plate of the present invention, the inside of a picowell comprises a material that delays adhesion of living cells thereto, that is the picowell is substantially fashioned from the adhesion-delaying material or the inside of the picowell is coated with the adhesion-delaying material. A suitable material to coat the inside of a picowell or from which to make a picowell comprises polydimethylsiloxane, is substantially polydimethylsiloxane or is substantially pure polydimethylsiloxane.

10 In an embodiment of the present invention bottom surfaces of picowells making up a plurality of picowells of a plate comprise a material having an index of refraction similar to that of water. In a preferred embodiment of a plate of the present invention, the index of refraction of the bottom surfaces is less than about 1.4, less than about 1.38, less than about 1.36, less than about 1.35, less than about 1.34 or substantially equal to that of water.

In an embodiment of the present invention, the plurality of picowells comprises picowells having an inner surface coated with a layer of a material. Suitable materials for coating an inner surface of a picowell of a plate of the present invention include but are not limited to gels, hydrogels, polydimethylsiloxane, elastomers, polymerized para-xylylene molecules, polymerized derivatives of para-xylylene molecules, rubber and silicon rubber.

In an embodiment of the present invention, a plate of the present invention further comprises a gel cover covering a plurality of the picowells, the cover made of a gel. Suitable gels are as described hereinabove.

25 In an embodiment of the present invention, substantially the entire bottom surface of a well is covered by a respective plurality of picowells.

In an embodiment of the present invention, a plate further comprises at least one additional feature functionally associated with the plurality of picowells, especially microfluidic features. Suitable microfluidic features include but are not limited to channels, coupling elements, drains, fluid channels, fluid reservoirs, input ports, membranes, microreactors, microvalves, output ports, passages, plumbing routes,

- 13 -

protruberances, pumps, transport channels and valves. Other suitable features include but are not limited to light sources, magnetizable elements, optical components, optical fibers, optical filters, protruberances, fiducial points and walls.

5 In an embodiment of the present invention, a plate further comprises a cover slip, the cover slip and a plurality of picowells in a well configured so as to allow the cover slip to rest above the plurality of picowells substantially in parallel to the bottom surface of the well.

10 According to the teachings of the present invention, there is provided a method of making a multiwell plate of the present invention, comprising: (a) contacting a precursor material with a template including a negative of features of the plate so as to create the features in the precursor material, the features including the plurality of picowells; (b) fixing the features in the precursor material so as to fashion an incipient plate; and (c) processing the incipient plate so as to fashion the multiwell plate of the present invention.

15 Depending on the embodiment and the nature of the precursor material, fixing includes such methods as heating the precursor material, cooling the precursor material, polymerizing the precursor material, cross-linking the precursor material, curing the precursor material, irradiating the precursor material, illuminating the precursor material, gelling the precursor material, exposing the precursor material to a fixative and waiting a period of time.

20 The template is generally made of a material that is rigid compared to the precursor material. Suitable materials include but are not limited to reversibly deformable materials, irreversibly deformable materials, ceramics, epoxies, glasses, glass-ceramics, metals, plastics, polycarbonates, polydimethylsiloxane, polyethylenterephthalate glycol, polymers, polymethyl methacrylate, paraffins, polystyrene, polyurethanes, polyvinyl chloride, silicon, silicon oxide, silicon rubbers and wax.

30 Features created in the precursor material in addition to the plurality of picowells include such features as channels, coupling elements, drains, fluid channels, fluid reservoirs, input ports, light sources, magnetizable elements, membranes, microreactors, microvalves, passages, optical components, optical fibers, optical filters, output ports, plumbing routes, protruberances, pumps, transport channels, valves, walls and fiducial

points. In an embodiment of the present invention, the features created in the precursor material in addition to the plurality of picowells include the plurality of wells.

In an embodiment of the present invention, prior to contacting the template with the precursor material, the precursor material is placed in a well of a preexisting
5 multiwell plate.

In an embodiment of the present invention, subsequent to the fixing of the features, walls of the plurality of wells are attached to the incipient plate. Attaching includes the use of methods employing adhesives or surface treatments such as plasma treatments.

10 In an embodiment of the present invention the precursor material is an irreversibly deformable material (*vide infra*) such as a wax, a paraffin, plastic or polymer, and fixing the features simply includes separating the template from the precursor material.

In an embodiment of the present invention the precursor material is a reversibly
15 deformable material (*vide infra*) such as a gellable fluid, a polymerizable material, a powder, a fluid or a thermoplastic material.

In an embodiment of the present invention, the reversibly deformable precursor material is a thermoplastic material at plastic temperature and fixing the features includes cooling the thermoplastic material.

20 In an embodiment of the present invention, the reversibly deformable precursor material is a polymerizable material and fixing the features includes polymerizing the polymerizable material. Suitable polymerizable materials include but are not limited to monomer solutions, crosslinkable polymers, vulcanizable polymers, polymerizable fluid and thermosetting resins.

25 In a preferred embodiment, the polymerizable material is a polydimethylsiloxane precursor mixture and fixing the features includes polymerizing the polydimethylsiloxane precursor mixture so as to produce polydimethylsiloxane. In another preferred embodiment, the polymerizable material includes urethane and fixing the features includes polymerizing the urethane to produce polyurethane.

30 In an embodiment of the present invention, the reversibly deformable precursor material is a gellable fluid and fixing the features includes gelling the gellable fluid. Depending on the nature of the gellable fluid used, preferred methods of gelling the

gellable fluid include of heating the gellable fluid, cooling the gellable fluid, irradiating the gellable fluid, illuminating the gellable fluid, contacting the gellable fluid with a gelling reagent and waiting a period of time for the gellable fluid to gel. Suitable gellable fluids include but are not limited to agars, agaroses, gelatins, low melting
5 temperature agaroses, alginates, proteins, protein polysaccharides, room-temperature Ca^{2+} -inducible alginates and polysaccharides. A preferred gellable fluid is an alginate solution where gelling the gellable fluid includes contacting the gellable fluid with a gelling reagent, such as a gelling reagent including Ca^{2+} ions. An additional preferred gellable fluid is a low melting temperature agarose solution and gelling the gellable
10 fluid includes cooling the gellable fluid.

In an embodiment of the present invention, processing the incipient plate comprises coating an inside surface of picowells of the plurality of picowells with a layer of a coating material.

According to the teachings of the present invention there is provided an
15 additional method of making a multiwell plate of the present invention, comprising (a) placing a photoresist material on a precursor plate; and (b) fixing a plurality of picowells in the photoresist material. Preferably, the fixing of the plurality of picowells comprises irradiating the photoresist material through a mask. A precursor plate is made of a suitable material. Suitable materials include but are not limited to ceramics,
20 epoxies, glasses, glass-ceramics, metals, plastics, polycarbonates, polydimethylsiloxane, polymers, polyethyleneterephthalate glycol, polymethyl methacrylate, polystyrene, polyurethanes, polyvinyl chloride, silicon and silicon oxide.

In an embodiment of the method of the present invention the precursor plate
25 comprises a multiwell plate. The photoresist material is placed in a well of the precursor plate and the photoresist material irradiated inside the well.

In an embodiment of the present invention, subsequent to the fixing of the features, walls of the plurality of wells are attached to the precursor plate. Attaching includes the use of methods employing adhesives or surface treatments such as plasma treatments.

30 In an embodiment of the present invention, subsequent to fixing the picowells in the photoresist material, the inside surface of picowell of the plurality of picowells is coated with a layer of a coating material.

- 16 -

According to the teachings of the present invention, there is provided an additional method for making a multiwell plate of the present invention by placing a picowell-bearing component on a precursor plate. In a preferred embodiment, the picowell-bearing component is attached to the precursor plate. Attaching includes the use of methods employing adhesives or surface treatments such as plasma treatments. A suitable picowell-bearing component includes a carrier comprising a plurality of picowells disposed on a surface, such as a carrier described in PCT patent application IL01/00992 or in unpublished copending PCT patent application IL04/00571 of the Applicant filed 27 June 2004 (*vide infra*).

10 In an embodiment of the method of the present invention the precursor plate comprises a multiwell plate and the picowell-bearing component is placed in a respective well.

In an embodiment of the present invention, subsequent to the placing of the picowells-bearing component on the precursor plate, walls of the plurality of wells are attached to the precursor plate. Attaching includes the use of methods employing adhesives or surface treatments such as plasma treatments.

In an embodiment of the present invention, subsequent to placing the picowells on the precursor plate, the inside surface of picowells of the plurality of picowells are coated with a layer of a coating material.

20 As noted above, whatever method is used for making a multiwell plate of the present invention, it is often desired to coat the plurality of picowells, especially the inside surface of picowells with some material. Coating the inside surface of a picowell allows modification of the properties of the picowell, for example to reduce cytotoxicity, to change physical properties such as solvent resistance or permeability or to delay proliferation of cells held in a respective picowell. In an embodiment of the method of the present invention, coating the inside surface of picowells comprises (i) applying a precursor fluid to inside surfaces of the picowells; and (ii) solidifying the precursor fluid so as to form the layer. Suitable methods of solidifying include but are not limited to heating the precursor fluid, cooling the precursor fluid, polymerizing the precursor fluid, cross-linking the precursor fluid, curing the precursor fluid, irradiating the precursor fluid, illuminating the precursor fluid, gelling the precursor fluid, exposing the precursor fluid to a fixative and waiting a period of time.

In another embodiment of the method of the present invention, coating the inside of the wells comprises (i) depositing a vapor of the coating material onto the inside surface of the picowells thereby forming the layer of coating material.

In another embodiment of the present invention, coating the inside surface of the wells comprises (i) depositing a vapor of a coating precursor material onto the inside surface of the picowells; and (ii) solidifying the coating precursor material thereby forming the layer of the coating material. Suitable methods of solidifying the coating precursor material depend on the details of the specific embodiment and include but are not limited to heating the coating precursor material, cooling the coating precursor material, polymerizing the coating precursor material, cross-linking the coating precursor material, curing the coating precursor material, irradiating the coating precursor material, illuminating the coating precursor material, gelling the coating precursor material, exposing the coating precursor material to a fixative and waiting a period of time. In a preferred embodiment, the vapor of coating precursor material is a vapor of para-xylylene molecules or derivatives thereof and the layer comprises the polymerized para-xylylene molecules (or derivatives thereof). By para-xylylene derivatives is meant a molecule that is substantially a para-xylylene molecules having any additional substituent on either or both aromatic rings.

According to the teachings of the present invention there is also provided a device comprising an array of living cells held in a non-fluid matrix, where the matrix is configured to maintain cell viability. Preferably, the living cells are physically held in pockets in the matrix and there is substantially no bond between the living cells and the matrix. In a preferred embodiment, the array is substantially planar having an upper surface and a lower surface. In a preferred embodiment, one or both of the two surfaces is transparent to at least one wavelength of light or range of wavelengths of light in the ultraviolet, visible or infrared light spectrum.

In a preferred embodiment of the present invention, the matrix is configured to substantially delay the proliferation of living cells held therein.

In an embodiment of the device of the present invention the matrix comprises a material having an index of refraction similar to that of water. In a preferred embodiment of the device present invention, the index of refraction of the matrix is less

than about 1.4, less than about 1.38, less than about 1.36, less than about 1.35, less than about 1.34 or substantially equal to that of water.

One material from which a matrix is preferably made that generally has at least some of the preferred properties described above is a gel, especially a hydrogel. Suitable
5 gels are as described above for gel picowells of a multiwell plate of the present invention.

In a preferred embodiment of the present invention, the matrix further comprises an active entity. A preferred active entity is an indicator, especially an indicator configured to indicate a cell response to a stimulus, such as the release of a second
10 active entity.

According to the teachings of the present invention there is also provided a method for handling living cells, comprising: (a) providing an ordered array of living cells immobilized in a non-fluid matrix, the matrix configured to maintain cell viability; (b) contacting the living cells with a stimulus; and (c) detecting a response of the cells to
15 the stimulus. The method of handling living cells of the present invention is preferably implemented using the device of the present invention.

In an embodiment of the present invention, the matrix further comprises an active entity. A preferred active entity is an indicator, especially an indicator configured to indicate a cell response to a stimulus, such as the release of a second active entity.

20 In an embodiment of the present invention, part of the detecting a response comprises contacting the matrix with an active entity. A preferred active entity is an indicator, especially an indicator configured to indicate a cell response to a stimulus, such as the release of a second active entity. In some embodiments, it is required to wait a period of time so as to allow the contacted active entity to reach proximity with the
25 cells, for example by diffusion through the matrix.

In an embodiment of the present invention, detecting comprises detecting emitted light, for example light emitted by a cell or from an indicator, for example by fluorescence. In an embodiment of the present invention, detecting comprises detecting light, for example light reflected, diffracted, passing through or passing by a cell or an
30 indicator.

According to the teachings of the present invention there is provided a method for producing an ordered array of living cells in a non-fluid matrix, comprising: (a)

providing a multiwell plate provided with a plurality of wells, the multiwell plate including a plurality of picowells at the bottom of at least one well, the plurality of picowells including picowells; (b) placing a suspension of a plurality of living cells in a gellable fluid in the at least one well; (c) causing the living cells to settle into the
5 picowells so as to be held in respective picowells; and (d) gelling the gellable fluid so as to make a gel cover, trapping the living cells between the picowells and the gel cover. In an embodiment of the present invention, the picowells are made of a material comprising a gel.

Generally, causing the living cells to settle into the picowells includes applying a
10 force to the cells, typical forces including gravitation, centrifugal forces, forces resulting from the impact of photons on the cells (*e.g.*, laser tweezers, application of a non-focussed laser (see, for example, P.A.L.M. Microlaser Technologies AG, Bernried, Germany)), or forces resulting from a pressure wave (such as produced by an ultrasonic transponder).

15 In a preferred embodiment, prior to gelling the gellable fluid, it is ensured that each picowell holds no more than one living cell. In another preferred embodiment, prior to gelling the gellable fluid, it is ensured that each picowell holds no more than a predetermined number of living cell or holds a predetermined number of living cells.

In a preferred embodiment, the gellable fluid is chosen so that upon gelling a
20 transparent gel is formed. In a preferred embodiment, the gellable fluid is chosen so that upon gelling a hydrogel is formed.

Depending on the nature of the gellable fluid used, preferred methods of gelling the gellable fluid include of heating the gellable fluid, cooling the gellable fluid, irradiating the gellable fluid, illuminating the gellable fluid, contacting the gellable fluid
25 with a gelling reagent and waiting a period of time for the gellable fluid to gel. Gellable fluids suitable for use in in implementing the method of the present invention include but are not limited to agar gel solutions, agarose gel solutions, gelatin solutions, low melting temperature agarose gel solutions, alginate gel solutions, room-temperature Ca^{2+} -induced alginate gel solutions and polysaccharide gel solutions. Depending on the
30 embodiment, a gellable fluid has a water content of greater than about 80% by weight, greater than about 92% by weight, greater than about 95% by weight, greater than about 97% by weight and even greater than about 98% by weight. A preferred gellable fluid is

- 20 -

an alginate solution where gelling the gellable fluid includes contacting the gellable fluid with a gelling reagent, such as a gelling reagent including Ca^{2+} ions. An additional preferred gellable fluid is a low melting temperature agarose solution and gelling the gellable fluid includes cooling the gellable fluid. In an embodiment of the present invention, the gellable fluid further comprises an active entity. A preferred active entity is an indicator, especially an indicator configured to indicate a cell response to a stimulus, such as the release of a second active entity.

BRIEF DESCRIPTION OF THE DRAWINGS

10 The invention is herein described, by way of example only, with reference to the accompanying drawings. With specific reference now to the drawings in detail, it is stressed that the particulars shown are by way of example and for purposes of illustrative discussion of the preferred embodiments of the present invention only, and are presented in the cause of providing what is believed to be the most useful and readily understood description of the principles and conceptual aspects of the invention. In this regard, no attempt is made to show structural details of the invention in more detail than is necessary for a fundamental understanding of the invention, the description taken with the drawings making apparent to those skilled in the art how the several forms of the invention may be embodied in practice.

20 In the drawings:

FIG. 1 (prior art) depicts a cell-chip device of PCT patent application IL01/00992 including a transparent carrier;

FIG. 2 (prior art) is a reproduction of a photograph of a cell-chip device of PCT patent application IL01/00992;

25 FIG. 3 (prior art) is a reproduction of a photograph of a cell-populated well-array of a carrier of a cell-chip device of PCT patent application IL01/00992;

FIG. 4 (prior art) is a schematic depiction of a standard commercially available 96-well plate;

30 FIGS. 5A-5B are reproduction of photographs of a 96-well plate of the present invention showing wells and picowells;

FIG. 6 is a reproduction of a scanning electron micrograph of an array of picowells of a multiwell plate of the present invention;

FIG. 7 is a schematic depiction of a side view of picowells of the present invention configured as enclosures;

FIG. 8 is a reproduction of a scanning electron micrograph of the domes on a nickel template used for the production of a plurality of picowells of the present invention;

FIGS. 9A-9F are schematic depictions of steps of a method of the present invention for making a multiwell plate of the present invention by contacting a template bearing negatives of wells and a pluralities of picowells with a reversibly deformable precursor material;

FIGS. 10A-10C are schematic depictions of steps of a method of the present invention for making a multiwell plate of the present invention by contacting a template bearing negatives of a plurality of picowells with a reversibly deformable precursor material inside a well of preexisting multiwell plate;

FIGS. 11A-11E are schematic depictions of steps of a method of the present invention for making a multiwell plate of the present invention by contacting a template bearing negatives of pluralities of picowells with a reversibly deformable precursor material followed by attachment of a separate well-wall component;

FIGS. 12A-12D are schematic depictions of steps of a method of the present invention for making a multiwell plate of the present invention by producing picowells on a flat precursor plate using photolithography followed by attachment of a separate well-wall component;

FIGS. 13A-13C are schematic depictions of steps of a method of the present invention for making a multiwell plate of the present invention by producing pluralities of picowells by photolithography inside wells of a preexisting multiwell plate;

FIGS. 14A-14C are schematic depictions of steps of a method of the present invention for making a multiwell plate of the present invention by attaching preexisting picowell-bearing carriers inside wells of a preexisting multiwell plate;

FIGS. 15A-15C are schematic depictions of steps of a method of the present invention for making a multiwell plate of the present invention by attaching preexisting picowell-bearing carriers to a substantially flat precursor plate followed by attachment of a separate well-wall component;

- 22 -

FIG. 16 is a schematic depiction of a device of the present invention being substantially a 3 by 3 array of living cells held in a non-fluid matrix; and

FIG. 17 is a schematic depiction of a 96-well plate of the present invention comprising arrays of living cells in a non-fluid matrix.

5

DETAILED DESCRIPTION OF THE INVENTION

The present invention is of a multowell plate having a plurality of picowells on the bottom of the wells of the plate. The present invention is also of methods of producing a multowell plate of the present invention. The present invention is also of a device comprising an array of living cells held in a non-fluid matrix. The present invention is also of a method of handling living cells by providing an ordered array of living cells immobilized in a non-fluid matrix, contacting the living cells with a stimulus; and detecting a response to the stimulus. The present invention is also of a method of producing an ordered array of living cells.

15 The principles and uses of the teachings of the present invention may be better understood with reference to the accompanying description, figures and examples. In the figures, like reference numerals refer to like parts throughout.

Before explaining at least one embodiment of the invention in detail, it is to be understood that the invention is not limited in its application to the details set forth herein. The invention can be implemented with other embodiments and can be practiced or carried out in various ways. It is also understood that the phraseology and terminology employed herein is for descriptive purpose and should not be regarded as limiting.

25 Generally, the nomenclature used herein and the laboratory procedures utilized in the present invention include techniques from the fields of biology, chemistry and engineering. Such techniques are thoroughly explained in the literature. Unless otherwise defined, all technical and scientific terms used herein have the same meaning as commonly understood by one of ordinary skill in the art to which the invention belongs. In addition, the descriptions, materials, methods, and examples are illustrative only and not intended to be limiting. Methods and materials similar or equivalent to those described herein can be used in the practice or testing of the present invention. All publications, patent applications, patents and other references mentioned are

30

incorporated by reference in their entirety as if fully set forth herein. In case of conflict, the specification herein, including definitions, will control.

As used herein, the terms "comprising" and "including" or grammatical variants thereof are to be taken as specifying the stated features, integers, steps or components
5 but do not preclude the addition of one or more additional features, integers, steps, components or groups thereof. This term encompasses the terms "consisting of" and "consisting essentially of".

The phrase "consisting essentially of" or grammatical variants thereof when used herein are to be taken as specifying the stated features, integers, steps or components but
10 do not preclude the addition of one or more additional features, integers, steps, components or groups thereof but only if the additional features, integers, steps, components or groups thereof do not materially alter the basic and novel characteristics of the claimed composition, device or method.

The term "method" refers to manners, means, techniques and procedures for
15 accomplishing a given task including, but not limited to, those manners, means, techniques and procedures either known to, or readily developed from known manners, means, techniques and procedures by practitioners of the chemical, pharmacological, biological, biochemical and medical arts. Implementation of the methods of the present invention involves performing or completing selected tasks or steps manually,
20 automatically, or a combination thereof.

Herein, the term "active entity" is understood to include chemical, biological or pharmaceutical entities including any natural or synthetic chemical or biological substance that influences a cell with which the entity is in contact. Typical active entities include but are not limited to active pharmaceutical ingredients, antibodies,
25 antigens, biological materials, chemical materials, chromatogenic compounds, drugs, enzymes, fluorescent probes, immunogenes, indicators, ligands, nucleic acids, nutrients, peptides, physiological media, proteins, receptors, selective toxins and toxins.

Herein, by "indicator" is meant any active entity that upon interaction with some stimulus produces an observable effect. In the context of the present invention, by
30 stimulus is meant, for example, a specific second active entity (such as a molecule) released by a cell and by observable effect is meant, for example, a visible effect, for example a change in color or emission of light.

Some embodiments of the present invention include components that are transparent or are made of a transparent material. By "transparent" is meant that the component or material is substantially transparent to radiation having a wavelength in at least part of the visible light spectrum, the ultraviolet light spectrum and/or of infrared radiation, preferably the visible light spectrum.

It is important to note that some embodiments of the present invention are related to embodiments of unpublished copending PCT patent application IL04/00571 of the Applicant filed 27 June 2004. In IL04/00571 are taught picowell-bearing carriers having a variety of innovative features. One aspect of the teachings of PCT patent application IL04/00571 is of picowells configured to influence cell proliferation of cells held therein. In one embodiment, carriers having picowells of a changeable size is taught. In another embodiment, carriers configured to delay proliferation of cells held therein, for example by delaying or preventing cell adhesion, are taught. In another embodiment, carriers configured so as to allow cells to grow into or through the carrier are taught. The above-described embodiments are preferably implemented by making the picowells of or coating the picowells with a material with the desired properties. In some embodiments, the inner surface of a picowell with which a held cell makes contact is configured to have the desired property, influence or effect. Preferred materials from which to make carriers listed in PCT patent application IL04/00571 include polydimethylsiloxane, elastomers (such as silicon rubber), polymerized para-xylylene molecules, polymerized derivatives of para-xylylene molecules and gels (especially hydrogels). In some embodiments, the inner surface of a picowell with which a held cell makes contact is configured to have the desired property, influence or effect.

An additional aspect of PCT patent application IL04/00571 are the teachings of a gel cover for picowell bearing components. The gel cover is configured to prevent cells held in a picowell from exiting the picowell due to jostling, incidental fluid flows or during movement of the carrier.

The advantages of a picowell-bearing carrier made of a gel, of a picowell gel-cover or a gel carrier covered with a gel cover include, depending on the embodiment, that active entities may be integrated into the gel, that active entities may be contacted with the cell by diffusion through the gel, that diffusion of released compounds is slowed down allowing identification of which cell released a given compound, that

proliferation of cells held therein is delayed but once cells begin to proliferate, that allows proliferation into and through the gel matrix.

As discussed hereinabove, a prior art multiwell plate is substantially a planar device having an upper surface whereupon is found an array of wells configured to hold
5 a fluid containing cells or other entities. As noted above, multiwell plates generally have a standard footprint of *ca.* 8.5 cm by *ca.* 12.5 cm. As noted above, the wells of a prior art multiwell plate are generally distributed in a standard $2n$ by $3n$ rectangular packed well-array, n being an integer. The standard multiwell plates have 6, 12, 48, 96, 384 or
10 even 1536 standard sized wells. The volume of the wells depends on the number of wells and the depth thereof but is generally greater than 5×10^{-6} liter (for a 1536 well plate). In Figure 4 is depicted a top view of a prior art 96-well plate **42** from the top, comprising 96 wells **44** arranged in a 8 by 12 array.

The present invention provides an improved multiwell plate where at the bottom surface of at least one of the wells (preferably substantially all of the wells) are a
15 plurality of picowells. Figures 5 are top views of a multiwell plate of the present invention. With no magnification, a plate of the present invention looks like prior art plate **42** depicted in Figure 4. Magnification of a single well **44** of the 96 wells reveals that at the bottom of a well **44** is found an array **18** of hexagonally packed 20 micron hexagonal picowells **46**, Figures 5A and 5B. In one embodiment, substantially the entire
20 bottom surface of such a well comprises picowells (as depicted in Figure 5A). In one embodiment of the multiwell plate of the present invention, the picowell-containing wells are homogenous, that is all have substantially the same size and arrangement of picowells (as depicted in Figure 5A). In another embodiment of the multiwell plate of the present invention, the picowell-containing wells are heterogenous, that is there is
25 variation between wells, for example variation in the size of the picowells, the arrangement of the picowells or the material from which the picowells are made or with which the picowells are coated.

The present invention also provides methods of making multiwell plates of the present invention. According to one embodiment of the method of the present invention,
30 a preexisting multiwell plates is converted into a multiwell plates of the present invention. According to another embodiment of the method of the present invention, a multiwell plates of the present invention is fashioned in one piece, the wells and the

- 26 -

picowells being integrally formed components of the multiwell plate. According to another embodiment of the method of the present invention, a multiwell plates of the present invention is fashioned by attaching a component or a plurality of components that is substantially the walls defining the wells to a second component, where the
5 second component is substantially a plate bearing the picowells of the multiwell plate.

Multiwell plate of the present invention

As stated hereinabove, a multiwell plate of the present invention is substantially a multiwell plate having a plurality of wells wherein at the bottom surface of at least one
10 well of the plate is found a plurality of picowells. Preferably, such a plate has a footprint of a standard multiwell plate. Preferably, the wells of the plurality of wells of such a plate are arranged in a manner similar or substantially identical to the arrangement of wells of a standard multiwell plate, that is, a rectangular packing of $6n$ wells arranged in a $2n$ by $3n$ array, where n is an integer greater than 0. Preferred are the most common
15 multiwell plate formats, that is, 6, 24, 96, 384 and 1536 wells, 96-wells and 384-wells being most preferred. Preferably, the individual picowells of the plurality of picowells are individually addressable. For ease of optical study and observation, it is preferred that the bottoms of all the picowells of a certain well or of the entire plate be substantially coplanar: coplanarity allows for optical observation of many cells (whether
20 by scanning or simultaneously using a wide-angle observation component) without the need for time consuming and technically difficult to implement refocusing.

The use of a multiwell plate of the present invention allows efficient study of pluralities of living cells as individuals.

On the one hand, standard accessories available in the art for manipulating and
25 using multiwell plates including robotic plate handlers, robotic fluid dispensers, multipipettes, multifilters and the like are useable with the multiwell plates of the present invention. Further, the format of the wells of prior art multiwell plates has proven to be convenient for the performance of many simultaneous experiments in the field of cellular biology, for example, during combinatorial studies.

30 On the other hand, cells placed in a well of a multiwell plate of the present invention are held in the picowells of a respective plurality of picowells. The effect is that a plurality of cells held in a multiwell plate of the present invention are arranged in

a rationally ordered array. The rational arrangement of cells eases observation (especially when the bottoms of the picowells are coplanar) and makes the cells more easily observable as individuals (especially when the picowells are individually addressable). Held cells are isolated from direct physical contact with other cells,
5 improving the quality of experimental results.

In an embodiment of the present invention, the picowells of the plurality of picowells of a well are juxtaposed. By juxtaposed is meant that in an area where picowells are found, most of the area is picowell area and little of the area is inter picowell area. For example, in embodiments of the present invention, the inter picowell
10 area between two picowells is less than or equal to 0.35, 0.25, 0.15, 0.10 or even 0.06 of the sum of the areas of the two picowells. In a preferred embodiment, the inter picowell area is substantially nonexistent, for example when the rims of picowells are substantially knife-edged. A picowell-array having substantially no inter picowell area is seen in Figure 5B. In Figure 6, a reproduction of a scanning electron micrograph of a
15 picowell-array of a multiwell plate of the present invention having knife-edged rims is shown. One advantage of juxtaposed picowells is that when cells are placed in a respective well, the cells settle into picowells and do not settle onto inter picowell areas. Further, when a plurality of juxtaposed picowells is used, a near-tissue density planar array of cells is achieved. For example, an array of 10-micron wide hexagonal packed
20 knife-edged picowells has a picowell density of about 1.5×10^6 picowells cm^{-1} .

Further, for reasons of a simple loading procedure and a high picowell density, in a preferred embodiment of the present invention, a plurality of picowells covers substantially the entire bottom surface of a respective well, as depicted in Figures 5.

As the teachings of the present invention are directed to cellular biology, it is
25 generally preferred that the picowells be small so as to avoid having a large number of cells held in any one picowell. Thus, generally, the dimensions of the picowells are generally less than about 200, 100, 50, 25 or even 10 microns. By dimensions is meant the usual meaning of the word and is dependent on the shape of the picowell. For example, for hexagonal or circular picowells, the term dimension refers to diameter. For
30 square or triangular picowells is meant the longest dimension of the square or triangle, respectively. The exact dimensions of individual picowells depends on the type (and consequently size) of cells to be studied and the types of experiments and studies that

are to be performed. Since different types of cells have different sizes, generally a multiwell plate of the present invention has picowells of a size to accommodate one or more cells of the type to be studied. In some embodiments it is preferred that an individual picowell be of a size so as to hold no more than one living cell of a certain size. In other embodiments it is preferred that the picowell be of a size so as to hold no more than a predetermined number of cells of a certain size (e.g., two or three cells simultaneously).

In some embodiments of the present invention, picowells are dimples or depressions on the bottom surface of the inside of a well of a multiwell plate, as seen in Figure 6. In other embodiments, depicted in side view in Figure 7, picowells 46 are substantially enclosures of dimensions so that at least one cell 48 of a certain size is containable, substantially entirely, within the enclosure, each enclosure having an opening 50 at the surface, the opening defined by a first cross section of a size allowing passage of cell of the certain size 48. The exact dimensions of the individual enclosures depends on the type (and consequently size) of cells to be studied and the types of experiments and studies that are to be performed. The volume of such enclosure picowells is typically less than 1×10^{-11} liter (corresponding to the volume of a 200 micron cube), less than 1×10^{-12} liter (corresponding to the volume of a 100 micron cube), less than 1×10^{-13} liter (corresponding to the volume of a 50 micron cube), less than 1×10^{-14} liter (corresponding to the volume of a 25 micron cube) and even less than 1×10^{-15} liter (corresponding to the volume of a 10 micron cube). The area of the first cross section, corresponding to the size of the opening of a respective enclosure is typically less than about 40000 micron² (corresponding to the area of a 200 micron square), 10000 micron² (corresponding to the area of a 100 micron square), 2500 micron² (corresponding to the area of a 50 micron square), 625 micron² (corresponding to the area of a 25 micron square) or even less than about 100 micron² (corresponding to the area of a 10 micron square).

In embodiments of the present invention, all the picowells of all the pluralities of picowells in all the wells of the multiwell plate of the present invention are substantially identical in size. In embodiments of the present invention, the plurality of picowells in one well is substantially different from the plurality of picowells in a second well. For example, in an embodiment of the present invention the size of the picowells of the

plurality of picowells in one well is different from the size of the picowells of the plurality of picowells in a second well. In embodiments of the present invention, the plurality of picowells in one well includes picowells of different sizes or shapes. For example, in an embodiment of the present invention, one well includes 10 micron
5 picowells together with 20 micron micron picowells.

A multiwell plate of the present invention is made of any suitable material. Suitable materials include but are not limited to ceramics, elastomers, epoxies, glasses, glass-ceramics, metals, plastics, polycarbonates, polydimethylsiloxane, polyurethane, polyethylenterephthalate glycol, polymers, polymethyl methacrylate, polystyrene,
10 polyvinyl chloride, rubber, silicon, silicon oxide and silicon rubber. In an embodiment of the present invention, the bottom surface of the wells is made of any suitable material. Suitable materials include but are not limited to ceramics, elastomers, epoxies, glasses, glass-ceramics, metals, polymers, plastics, polycarbonates, polydimethylsiloxane, polyethylenterephthalate glycol, polymethyl methacrylate,
15 polystyrene, polyurethane, polyvinyl chloride, rubber, silicon, silicon oxide and silicon rubber.

In embodiments of the present invention, an entire plate of the present invention and all components thereof are made of one material. In other embodiments, a plate of the present invention is made up of a number of different materials, for example, as a
20 plurality of layers or as a coated structure.

In an embodiment of the present invention, the walls of wells are integrally formed with the bottom surface of the wells. In embodiments, a multiwell plate of the present invention comprises at least one distinct well-wall component attached to the bottom surface. Such a distinct well-wall component is made of any suitable material.
25 Suitable materials include but are not limited to ceramics, elastomers, epoxies, glasses, glass-ceramics, metals, plastics, polycarbonates, polydimethylsiloxane, polyethylenterephthalate glycol, polymers, polyurethane, polymethyl methacrylate, polystyrene, polyvinyl chloride, rubber, silicon, silicon oxide and silicon rubber.

In embodiments of the present invention, a plurality of picowells is integrally
30 formed with the bottom surface of a respective well.

In embodiments of the present invention, a multiwell plate of the present invention comprises at least one distinct picowell-bearing component bearing a plurality

- 30 -

of picowells, the component resting in or attached to the bottom surface of a respective well. A suitable distinct picowell-bearing component is a carrier comprising a plurality of picowells disposed on a surface, such as a carrier described in PCT patent application IL01/00992 or in unpublished copending PCT patent application IL04/00571 of the Applicant filed 27 June 2004. Picowell-bearing components are made of any suitable material, including reversibly deformable materials and irreversibly deformable materials. Suitable materials include but are not limited to gels, hydrogels, waxes, hydrocarbon waxes, crystalline waxes, paraffins, ceramics, elastomers, epoxies, glasses, glass-ceramics, metals, plastics, polycarbonates, polydimethylsiloxane, polyethyleneterephthalate glycol, polymers, polymethyl methacrylate, polystyrene, polyurethane, polyvinyl chloride, rubber, silicon, silicon oxide and silicon rubber.

In an embodiment of the multiwell plate of the present invention, a picowell-bearing component comprises a gel, preferably a transparent gel, preferably a hydrogel. Gel picowell-bearing components are discussed in detail in PCT patent application IL04/00571. As will be discussed in detail hereinafter, in general a gel picowell-bearing component of the present invention is advantageously produced by placing a gellable fluid in a well of an existing multiwell plate, contacting the gel with a template including, amongst others, negatives of the picowells, and then gelled. Gels suitable for use in making a picowell-bearing component of a plate of the present invention include but are not limited to agar gels, agarose gels, gelatins, low melting temperature agarose gels, alginate gels, room-temperature Ca^{2+} -induced alginate gels and polysaccharide gels. Depending on the embodiment, a suitable gel has a water content of greater than about 80% by weight, greater than about 92% by weight, greater than about 95% by weight, greater than about 97% by weight and even greater than about 98% by weight. Two exceptionally preferred types of hydrogels are alginates and low melting temperature agaroses.

Alginates are biologically compatible polysaccharide proteins that are fluid at low calcium ion concentrations (*e.g.*, $[\text{Ca}^{2+}] < 1 \mu\text{M}$) but gel upon exposure to higher concentrations of calcium ions (*e.g.*, $[\text{Ca}^{2+}] = 20 \text{ mM}$). An exceptionally suitable alginate for implementing the teachings of the present invention is sodium alginate and may be purchased, for example, from Pronova Biopolymers (Drammen, Norway) as Protanal LF120 1% in water or Protanal LF200 1% in water.

Low melting temperature agaroses are biologically compatible gels that before gelling are fluid at temperatures that do not harm living cells (*e.g.*, 20°C), gel at low temperatures that do not harm living cells (*e.g.*, 4°C) and remain stable until well-above temperatures used for studying living cells (40°C). An exceptionally suitable agarose for
5 implementing the teachings of the present invention that may be purchased, for example, from Cambrex Bio Science Rockland Inc. (Rockland, ME, USA) is HGS-LMP Agarose (catalogue nr. 50221).

In an embodiment, the gel includes an active entity. Suitable active entities include, but are not limited to antibodies, antigens, biological materials, chemical
10 materials, chromatogenic compounds, drugs, enzymes, fluorescent probes, immunogenes, indicators, ligands, nucleic acids, nutrients, peptides, physiological media, proteins, receptors, selective toxins and toxins.

In an embodiment of the present invention, picowells have a bottom surface made of a first material and borders, such as the borders delineating the picowells, made
15 of a second material, the second material being substantially different from the first material. In an embodiment of the present invention the first material is substantially the material from which the bottom of the well is made, for example when the bottom surface of the picowell is substantially the bottom surface of the well. In an embodiment of the present invention, the second material is a fixed photoresist material. As is
20 detailed hereinbelow, such a picowell structure is achieved by fixing a photoresist material applied to a precursor plate. An advantage of such like plates is that features such as picowells having flat bottom surfaces are easily made.

In an embodiment of the multiwell plate of the present invention, picowells are configured with an inside surface configured to delay proliferation of cells held therein,
25 for example by delaying adhesion of living cells thereto. Picowells configured to delay proliferation of living cells held therein are discussed in detail in PCT patent application IL04/00571. In an embodiment of the plate of the present invention, the inside of a picowell comprises a material that delays adhesion of living cells thereto, that is the picowell is substantially fashioned from the adhesion-delaying material or the inside of
30 the picowell is coated with the adhesion-delaying material. A suitable material to coat the inside of a picowell or from which to make a picowell comprises polydimethylsiloxane, is substantially polydimethylsiloxane or is substantially pure

polydimethylsiloxane. Suitable polydimethylsiloxane resins for coating picowells or to make picowells are commercially available and can be purchased, amongst others, under the trade names RTV615 PDMS (GE Silicones, Wilton, CT, USA) and Sylgard 184 PDMS (Dow Corning Corporation, Midland, MI, USA).

5 In an embodiment of the multiwell plate of the present invention, bottom surfaces of the picowells comprise a material having an index of refraction similar to that of water, that is an index of refraction of less than about 1.4, less than about 1.38, less than about 1.36, less than about 1.35, less than about 1.34 or substantially equal to that of water. Picowells having indices of refraction similar to that of water are
10 discussed in detail in PCT patent application IL04/00571. An advantage of such picowells is that observation of cells is simplified as the picowell walls are substantially invisible and there is little, if any, scattering, reflection and diffraction of light, that otherwise interferes with optical study of held cells, for example, during morphological studies using a microscope.

15 In an embodiment of the present invention, the plurality of picowells comprises picowells having an inner surface coated with a layer of a material. Suitable materials for coating an inner surface of a picowell of a plate of the present invention include but are not limited to gels, hydrogels, polydimethylsiloxane, elastomers, polymerized para-xylylene molecules, polymerized derivatives of para-xylylene molecules, rubber and
20 silicon rubber. Picowells having coated inner surfaces are discussed in detail in PCT patent application IL04/00571.

In an embodiment of the present invention, a plate of the present invention further comprises a gel cover covering a plurality of the picowells, the cover made of a gel. Suitable gels are as described herein. Gel picowell covers are discussed in detail in
25 PCT patent application IL04/00571.

In an embodiment of the present invention, a multiwell plate of the present invention further comprises at least one additional feature functionally associated with the plurality of picowells, especially a microfluidic feature. Suitable microfluidic features include but are not limited to channels, coupling elements, drains, fluid
30 channels, fluid reservoirs, input ports, membranes, microreactors, microvalves, output ports, passages, plumbing routes, protruberances, pumps, transport channels and valves. Other suitable features include but are not limited to light sources, magnetizable

elements, optical components, optical fibers, optical filters, protuberances, fiducial points and walls. Such an embodiment can be considered to be a multiwell plate of the present invention that holds a carriers such as described in PCT patent application IL01/00992 or in unpublished copending PCT patent application IL04/00571. Such an
5 embodiment allows performance of many and varied experiments to study living cells, as described in the above references.

In an embodiment of the of the present invention, a multiwell plate further comprises a cover slip, the cover slip and a plurality of picowells in a well configured so as to allow the cover slip to rest above the plurality of picowells substantially in parallel
10 to the bottom surface of the respective well. Such a cover slip can include microelectrodes to assist in manipulation of cells held in picowells, can be used in conjunction with other features so as to provide a microfluidics system for the picowells, or for other reasons as discussed in PCT patent application IL01/00992.

15 *Methods of manufacture of a multiwell plate of the present invention*

A multiwell plate of the present invention is produced using any suitable method known in the art. Suitable methods include methods that employ one or more techniques including but not limited to casting, embossing, etching, free-form manufacture, injection-molding, microetching, micromachining, microplating, molding, spin coating,
20 lithography or photo-lithography.

The preferred methods of producing a multiwell plate of the present invention are the methods of the present invention.

A first method of the present invention for making a multiwell plate of the present invention is substantially by contacting a precursor material with a template, the
25 template having a negative of some of the features of the plate (especially the picowells) thus creating the features in the precursor material. The features are subsequently fixed in the precursor material making an incipient plate. After any further processing of the incipient plate required (which may be limited to simply separating the template from the incipient plate), the multiwell plate of the present invention is fashioned.

30 Depending on the precursor material, fixing includes, but is not limited to, methods such as heating the precursor material, cooling the precursor material, curing the precursor material, polymerizing the precursor material, cross-linking the precursor

material, irradiating the precursor material, illuminating the precursor material, gelling the precursor material, exposing the precursor material to a fixative and waiting a period of time. By fixative is meant an agent that causes the precursor material to change to the fixed state and is used herein as a general term for such materials as fixatives, 5 hardeners, polymerization / crosslinking / curing initiators, catalysts and agents. It is important to note that in some cases a precursor material is produced by mixing two or more components which thereafter change to a fixed state, for example, by simply waiting a period of time.

In one preferred embodiment of the present invention, the precursor material is a 10 irreversibly deformable precursor material. Herein by irreversibly deformable precursor material is meant a material that does not recover a shape after deformation and so there is usually no need for a separate action to fix the features in the precursor material beyond separating the produced multiwell plate from the template. In such cases, the precursor material does not substantially chemically change subsequent to contact with 15 the template. Examples of suitable irreversibly deformable precursor materials include waxes, paraffins, plastics, polymers and the like. In such an embodiment, a preferred template is a stamp, and the contacting of the template with the precursor material is substantially stamping the features of the multiwell plate into the precursor material, preferably under controlled thermal conditions.

20 In another preferred embodiment of the present invention, the precursor material is a reversibly deformable precursor material. Herein by reversibly deformable precursor material is meant a material that is capable of recovering shape after deformation and includes gellable fluids, polymerizable materials, powders, fluids and thermoplastic materials.

25 In a preferred embodiment, the reversibly deformable precursor material is a thermoplastic material at a pliable temperature. Subsequent to the contacting of the template but before the contact is finished, the thermoplastic material is cooled, thus fixing the desired features in the incipient multiwell plate.

In another preferred embodiment, the reversibly deformable precursor material 30 is a polymerizable material (*e.g.*, a monomer solution, a crosslinkable polymer, a vulcanizable polymers, a polymerizable fluids or a thermosetting resin). Subsequent to the contacting of the template but before the contact is finished, the polymerizable

material is polymerized, thus fixing the desired features in the incipient multiwell plate. In such cases, the precursor material and the material from which the multiwell plate is made are chemically dissimilar (for example, have the relationship of monomer to polymer).

5 One preferred polymerizable precursor material is a non-cured polydimethylsiloxane precursor mixture. A mixture of two polydimethylsiloxane components (the prepolymer and curing agent) are mixed together in the desired ratio (preferably about 10:1, but ratios between about 5:1 and about 20:1 are generally suitable) to give a polydimethylsiloxane precursor mixture, the mixture degassed and
10 contacted with the template. The features are fixed by the curing of the mixture. Curing of polydimethylsiloxane precursor generally takes place at room temperature for about 24 hours and, when desired, is accelerated by heating. For example it has been found that multiwell plates of the present invention made of polydimethylsiloxane are ready for further processing within 2 hours when cured at 60°C or within 15 minutes when
15 cured at 150°C. A detailed review of methods for the production of micronic features such as picowells from polydimethylsiloxane suitable for implementing the teachings of the present invention are known in the art and discussed, for example, in Ng *et al.*, *Electrophoresis* **2002**, *23*, 3461-3473 and Duffy *et al.*, *Anal. Chem.* **1998**, *70*, 4974-4984.

20 Another preferred polymerizable precursor material is urethane that is polymerized to yield polyurethane.

 Another preferred reversibly deformable precursor material is a gellable fluid. After the gellable fluid is brought in contact with the template, the features are fixed by gelling the gellable fluid to yield a gel. Most preferred are gellable fluids that produce a
25 hydrogel.

 Gellable fluids known in the art include fluids that gel upon heating, fluids that gel upon cooling, fluids that gel upon irradiation or illumination, fluids that gel as a result of contact with a gelling reagent and fluids that gel after a period of time. Preferred gellable fluids for implementing the teachings of the present invention include
30 solutions of agars, agaroses, gelatins, low melting temperature agaroses, alginates, proteins, protein polysaccharides, Ca²⁺-inducible alginates (especially those that gel at room temperature) and polysaccharides.

- 36 -

One preferred gellable fluid is a low-melting temperature agarose solution. Such a solution is fluid at temperatures that do not harm living cells (*e.g.*, 20°C) and gel at low temperatures that do not harm living cells (*e.g.*, 4°C). An exceptionally suitable agarose for implementing the teachings of the present invention that may be purchased, 5 for example, from Cambrex Bio Science Rockland Inc. (Rockland, ME, USA) is HGS-LMP Agarose 0.5% in PBS (catalogue nr. 50221).

Another preferred gellable fluid is an alginate solution which gels upon contact with a gelling reagent, the preferred gelling reagent being a solution having a Ca²⁺ ion concentration of greater than about 1×10^{-6} M. An exceptionally useful gelling agent is 10 a 20×10^{-3} M calcium gluconate solution. Suitable alginate solutions can be purchased from Pronova Biopolymers (Drammen, Norway) and include, for example, Protanal LF120 1% in water and Protanal LF200 1% in water.

The template having a negative of the features is, for example, a stamp or a mold, and is generally made of any suitable material that is more rigid than a respective 15 precursor material. Suitable materials include but are not limited to reversibly deformable materials, irreversibly deformable materials, ceramics, epoxies, glasses, glass-ceramics, metals, plastics, polycarbonates, polydimethylsiloxane, polyethyleneterephthalate glycol, polymers, polymethyl methacrylate, paraffins, polystyrene, polyurethanes, polyvinyl chloride, silicon, silicon oxide, silicon rubbers 20 and wax.

The template is made, for example, using methods with which one skilled in the art is acquainted such as casting, embossing, etching, free-form manufacture, injection-molding, microetching, micromachining, microplating, molding, lithography or photolithography.

25 In Figure 8, is shown a reproduction of a scanning electron micrograph of the domes on a nickel stamp used as a template for the production of a multiwell plate of the present invention. Seen is an array of hexagonally-packed domes that are the negative of a hexagonal array of knife-edged picowells, such as seen in Figure 6. The diameter of the domes at the intersection with the nickel surface is approximately 20 30 microns.

In some embodiments, other features created in the precursor material by the contact of the template include features such as drains, channels, coupling elements,

drains, fiducial points, fluid channels, fluid reservoirs, input ports, microreactors, microvalves, passages, optical components, optical filters, output ports, plumbing routes, protruberances, protruberances for supporting a cover slip, pumps, transport channels, valves, walls and partial walls.

5 In some embodiments of the present invention, the wells of a multiwell plate of the present invention are made by contacting a precursor material with a template. Steps for producing a six-well plate of the present invention 52 according to a method of the present invention are schematically depicted in Figures 9. In Figure 9A, a fluid and therefore reversibly deformable precursor material 54 is provided. Precursor material 54
10 is a molten thermoplastic material. In Figure 9B, a template 56 substantially a nickel stamp having features that are negatives of features of plate 52 including wells and picowells is provided. In Figure 9C, template 56 is brought in contact with precursor material 54 so as to form the features of plate 52 in precursor material 54. In Figure 9D, the features of plate 52 are fixed in precursor material 54 by cooling so as to make
15 incipient plate 58. After sufficient cooling, template 56 is separated from incipient plate 58, Figure 9E. Incipient plate 58 undergoes whatever further processing is necessary to ultimately yield plate 52 of the present invention, having pluralities of picowells 18 in each one of six wells 44, Figure 9F.

 In a preferred embodiment, a multiwell plate of the present invention is made by
20 making picowells (and other desired features) as described above inside the wells of a preexisting multiwell plate. Suitable multiwell plates include but are not limited to plates made of reversibly deformable materials, irreversibly deformable materials, ceramics, epoxies, glasses, glass-ceramics, metals, plastics, polycarbonates, polydimethylsiloxane, polyethyleneterephthalate glycol, polymers, polymethyl
25 methacrylate, polystyrene, polyurethanes, polyvinyl chloride, silicon, silicon oxide and silicon rubbers. In such a case, the precursor material is placed into each desired well of the preexisting multiwell plate. A template is then placed inside the well so as to make contact with the precursor material and the precursor material is fixed as described above. Such an embodiment has the advantage that a commercially available multiwell
30 plate of any format (*e.g.*, 6, 24, 96, 384 and 1536 wells) and of virtually any material can be converted into a multiwell plate of the present invention. In such an embodiment a template can be made and used for fixing picowells and other features in any number

of wells including for each well separately or for all wells simultaneously. In this way, a single multiwell plate of the present invention having different features (*e.g.*, different sized picowells) in different wells is easily made.

Steps for producing a six-well plate of the present invention **52** according to a method of the present invention are schematically depicted in Figures 10. In Figure 5 10A, a fluid and therefore reversibly deformable precursor material **54** is placed in a preexisting 6-well plate **60** having six wells **44**. Precursor material **54** is a non-cured polydimethylsiloxane precursor mixture (comprising a mixture of a prepolymer and a curing agent). In Figure 10B, a template **56** substantially a nickel stamp having features 10 that are negatives of features of plate **52** found in wells **44** such as picowells and having a size and shape to precisely fit in a well **44** is contacted with precursor material **54** in each one of wells **44** sequentially so as to form the features of plate **52** in precursor material **54** in each one of wells **44** sequentially. Template **56** is maintained in contact with precursor material **54** in a given well **44** for so long as required for the desired 15 features to be fixed in precursor material **54** by solidification to be polydimethylsiloxane. In Figure 10B it is seen that at the bottom surfaces of each one of three wells **44a** are found a plurality of nanowells **18** while at the bottom of each one of three wells **44b** is found non-fixed precursor material **54**. Incipient plate **58** undergoes whatever further processing is necessary to ultimately yield plate **52** of the present 20 invention, having pluralities of picowells **18** in each one of six wells **44**, Figure 10C.

In another preferred embodiment, the template includes the negative of the desired features such as picowells but not of the wells. The template is contacted with the precursor material so as to form a substantially planar incipient plate having the features the negatives of which are found on the template. Subsequently, a grid-like 25 component, being substantially the walls of the wells of the multiwell plate of the present invention, is attached using an appropriate method, for example, adhesives (for example, light curable adhesives, such as light curing adhesive 3051 or 3341 manufactured by Henkel Loctite Deutschland GmbH, München, Germany) or surface treatments such as anodic bonding, fusion bonding or plasma treatment such as plasma discharge (exceptionally suitable for attaching polydimethylsiloxane, see Duffy *et al.*, 30 *Anal. Chem.* **1998**, *70*, 4974-4984).

Steps for producing a six-well plate of the present invention **52** according to a method of the present invention are schematically depicted in Figures 11. In Figure 11A, a fluid and therefore reversibly deformable precursor material **54** is provided. Precursor material **54** is a non-cured polydimethylsiloxane precursor mixture
5 (comprising a mixture of a prepolymer and a curing agent). In Figure 11A, a template **56** substantially a nickel stamp having features that are negatives of features of plate **52** such as picowells, but not wells is also provided. In Figure 11B, template **56** is brought in contact with precursor material **54** so as to form the features of plate **52** in precursor material **54**. Template **56** is maintained in contact with precursor material **54** for so long
10 as required for the desired features to be fixed in precursor material **54** by solidification to be polydimethylsiloxane and thus to produce a substantially planar incipient plate **58** having, amongst other features, six pluralities of nanowells **18**, Figure 11C. In Figure 11D, a grid-like component **64**, being substantially the walls of wells **44** of plate **52** of the present invention is provided. Attachment of grid-like component **64** to substantially
15 planar incipient plate **62** using adhesive (*e.g.*, light curing adhesive 3051 manufactured by Henkel Loctite Deutschland GmbH, München, Germany) and whatever further processing is necessary ultimately yields plate **52** of the present invention, having pluralities of picowells **18** in each one of six wells **44**, Figure 11E.

Another preferred method of making a multiwell plate of the present invention
20 includes photolithography of a photoresist material placed on a substrate, a commercially available process (for example, from Micro Resist Technology GmbH, Berlin, Germany) with which one skilled in the art is well-acquainted.

In brief, a high aspect ratio photoresist material (*e.g.*, SU-8 thick photoresist fluid, MicroChem Corporation, Newton MA, USA) is placed on a precursor plate as a
25 uniformly thick film. A preferred method of achieving a uniformly thin film of a photoresist fluid on a precursor plate is by spin coating, that is, the photoresist fluid is placed on a surface of the precursor plate and the precursor plate is rotated about an axis that is perpendicular to the surface of the substrate on which the photoresist fluid was placed. As a result of the rotation the photoresist fluid forms a uniformly thick film on
30 the precursor plate, typically between about 5 microns and about 20 microns thick. Once a film of uniform thickness of photoresist material is achieved, the photoresist material is illuminated through a mask, the mask being substantially a template or

- 40 -

master of the features which are desired to be fixed in the photoresist material including the desired picowells. Developing of the precursor with the selectively fixed film removes the non-fixed areas of the film. In such a way features of a multiwell plate of the present invention are made up of a fixed photoresist layer resting on a precursor
5 plate where the features of the multiwell plate are carved into the photoresist layer and the bottom of the features (such as picowells) is the surface of the precursor plate. Using a photolithography method, picowells and other features are easily produced, including features having a flat-bottom surface.

It is important to note that in addition to picowells, any suitable feature known in
10 the art and discussed herein for multiwell plates of the present invention or for picowell-bearing carriers described in PCT patent application IL 01/00992 or PCT patent application IL 04/00571 can also be added using the photoresist method. Such features include but are not limited to channels, coupling elements, drains, fluid channels, fluid reservoirs, input ports, microreactors, microvalves, passages, output ports, plumbing
15 routes, protruberances, pumps, transport channels, valves, walls and fiducial points.

The material from which the precursor plate is made can be any suitable material. Suitable materials include but are not limited to ceramics, epoxies, glasses, glass-ceramics, metals, plastics, polycarbonates, polydimethylsiloxane, polymers, polyethyleneterephthalate glycol, polymethyl methacrylate, polystyrene, polyurethanes,
20 polyvinyl chloride, silicon and silicon oxide.

Steps for producing a six-well plate of the present invention **52** according to a method of the present invention are schematically depicted in Figures 12. In Figure 12A, a flat precursor plate **66** is provided. In Figure 12B, the upper surface of flat precursor plate **66** is coated with a uniformly thin film of a precursor material **54**,
25 precursor material **54** being a photoresist fluid (e.g., SU-8 thick photoresist fluid, MicroChem Corporation, Newton MA, USA). In Figure 12C, precursor material **54** is illuminated through mask **68** using light source **70** so that features such as picowells are fixed in precursor material **54**. After the features are fixed, incipient plate **58** is developed so as to remove non fixed photoresist material and undergoes any further
30 processing necessary including attachment of a grid-like component **64** to ultimately yield plate **52** of the present invention, having pluralities of picowells **18** in each one of six wells **44**, Figure 12D.

- 41 -

In a preferred embodiment, the precursor plate comprises a multiwell plate. In such a case, the photoresist material (preferably a photoresist fluid) is placed into each desired well of the precursor plate and the photoresist material fixed by illumination as described above. Such an embodiment has the advantage that a commercially available
5 multiwell plate of any format (*e.g.*, 6, 24, 96, 384 and 1536 wells) and of virtually any material can be converted into a multiwell plate of the present invention. In such an embodiment a mask can be made and used for fixing picowells and other features in any number of wells including for each well separately or for all wells simultaneously. In this way, a single multiwell plate of the present invention having different features (*e.g.*,
10 different sized picowells) in different wells is easily made.

Steps for producing a six-well plate of the present invention **52** according to a method of the present invention are schematically depicted in Figures 13. In Figure 13A, a precursor material **54** is placed in an existing six-well plate **60** having six wells **44**. Precursor material **54** is a photoresist fluid (*e.g.*, SU-8 thick photoresist fluid,
15 MicroChem Corporation, Newton MA, USA). In Figure 13B, a probe **72** tipped with a mask **74** and provided with a light source **70** having a size and shape to precisely fit in a well **44** is brought in proximity with precursor material **54** in each one of wells **44** sequentially. During the time that mask **74** is in proximity with precursor material **54**, light source **70** is activated so that features such as picowells are fixed in precursor
20 material **54** in a respective well **44**. In Figure 13B it is seen that at the bottom surfaces of each one of three wells **44a** are found a fixed plurality of nanowells **18** while at the bottom of each one of three wells **44b** is found non-fixed precursor material **54**. After features are fixed in all desired wells **44**, incipient plate **58** is developed so as to remove non fixed photoresist material and undergoes any further processing necessary.
25 Ultimately a plate **52** of the present invention is formed having pluralities of picowells **18** in each one of six wells **44**, Figure 13C.

A preferred method for producing a multiwell plate of the present invention is by producing a substantially planar incipient plate where substantially the entire upper surface is provided with an array of picowells, whether by contact with a temple, by
30 photoresist or other methods. Subsequently a well-wall component or plurality of components is attached to the upper surface. The well-wall component thereby defines

the plurality of wells and the upper surface of the precursor plate is substantially the bottom surface of the wells whereupon the picowells are found.

Another preferred method of making a multiwell plate of the present invention comprises attaching one or more picowell-bearing components to a precursor plate
5 using an appropriate method, for example, using an adhesive or a surface treatment such as a plasma treatment, for example as described above. A preferred picowell-bearing component is a carrier comprising a plurality of picowells disposed on a surface. Preferred carriers include those described in PCT patent application IL 01/00992 or PCT patent application IL 04/00571.

10 In a preferred embodiment, the precursor plate comprises a multiwell plate. In such a case, one or more picowell-bearing components are placed into one or more wells of the precursor plate and attached using a suitable method. Such an embodiment has the advantage that a commercially available multiwell plate of any format (*e.g.*, 6, 24, 96, 384 and 1536 wells) and of virtually any material can be converted into a
15 multiwell plate of the present invention. In such a way many picowell-bearing components of different types are prefabricated, for example by mass production and placed as desired in as many wells of the precursor plate as desired. In this way, a single multiwell plate of the present invention having different features (*e.g.*, different sized picowells) in different wells is easily made.

20 Steps for producing a six-well plate of the present invention **52** according to a method of the present invention are schematically depicted in Figures 14. In Figure 14A, an adhesive **76** (*e.g.*, light curing adhesive 3051 manufactured by Henkel Loctite Deutschland GmbH, München, Germany) is placed in wells **44** of an existing six-well plate **60** having six wells **44**. In Figure 14B, carriers **26**, such as carrier **26** depicted in
25 Figure 2, are placed in each one of six wells **44** and illuminated with light source **70**. Adhesive **76** is cured by exposure to light produced by light source **70**, attaching each one of six carriers **26** inside a respective well **44**, producing a plate **52** of the present invention, having pluralities of picowells **18** in each one of six wells **44**, Figure 14C.

30 In another preferred embodiment, the precursor plate comprises a substantially planar plate, preferably having the same footprint of a multiwell plate (*ca.* 8.5 cm by *ca.* 12.5 cm). The picowell-bearing components are placed in appropriate locations on the precursor plate corresponding to the locations of one or more wells of the ultimately

made multiwell plate and attached using a suitable method. Subsequently, a grid-like component, being substantially the walls of the wells of the multiwell plate of the present invention, is attached using an appropriate method, for example, using an adhesive or a surface treatment such as a plasma treatment.

5 Steps for producing a six-well plate of the present invention **52** according to a method of the present invention are schematically depicted in Figures 15. In Figure 15A, a flat precursor plate **66** is provided. In Figure 15B, carriers **26**, such as carrier **26** depicted in Figure 2, are attached to flat precursor plate **66**, for example using an adhesive. Attachment of grid-like component **64** to incipient plate **58** and whatever
10 further processing is necessary ultimately yields plate **52** of the present invention, having pluralities of picowells **18** in each one of six wells **44**, Figure 15C.

It is important to note that in embodiments of the method of making a multiwell plate of the present invention by placing (and optionally attaching) preformed picowell-bearing components to a precursor plate, it is often advantageous that a given picowell-
15 bearing component have dimensions similar or substantially identical to that of a well in which the picowell-bearing component is attached. Such dimensions allow more exact placement of the picowell-bearing component in the well.

Some embodiments of the multiwell plate of the present invention comprise picowells where the inside surface of the picowells (with which held cells potentially
20 make physical contact) is coated with a layer of some desired coating material, for example a coating material that influences the proliferation of living cells as described in PCT patent application IL04/00571 .

One skilled in the art is acquainted with many ways and many coating materials with which to coat an inside surfaces of picowells of a multiwell plate of the present
25 invention.

One preferred method of coating inside surfaces of picowells of a multiwell plate of the present invention, applicable to virtually any multiwell plate produced by virtually any method, comprises contacting a precursor fluid with the inside surface of the picowells and subsequently solidifying the precursor fluid, forming the layer of the
30 coating material. Depending on the nature of the precursor fluid, solidifying is performed by any number of methods including but not limited to heating the precursor fluid, cooling the precursor fluid, polymerizing the precursor fluid, cross-linking the

precursor fluid, curing the precursor fluid, irradiating the precursor fluid, illuminating the precursor fluid, gelling the precursor fluid, exposing the precursor fluid to a fixative or waiting a period of time.

5 One preferred method of coating the inside surfaces of picowells of a multiwell plate of the present invention, applicable to virtually any multiwell plate produced by virtually any method, is by vapor deposition. Vapor deposition involves the deposition of materials such as molecules or atoms onto a surface at low pressures and is characterized by the production of evenly thin coatings on a surface, such as the inner surface of a picowell of a multiwell plate of the present invention.

10 In one embodiment of vapor deposition to the inside surfaces of picowells of a multiwell plate of the present invention, the atoms or molecules that make up the coating material are deposited. In another embodiment of vapor deposition, the atoms or molecules that comprise a precursor of the coating material are deposited on the inside surfaces of the picowells, followed by solidifying the coating precursor material thereby
15 forming the layer of coating material. Solidifying of the coating precursor material to form the layer of coating material is performed by any number of methods including but not limited to heating the coating precursor material, cooling the coating precursor material, polymerizing the coating precursor material, cross-linking the coating precursor material, curing the coating precursor material, irradiating the coating
20 precursor material, illuminating the coating precursor material, gelling the coating precursor material, exposing the coating precursor material to a fixative and waiting a period of time.

A preferred coating material for coating the inside surfaces of picowells of a multiwell plate of the present invention is made of polymerized para-xylylene
25 molecules (or derivatives thereof, specifically where one or more hydrogens, especially aromatic hydrogens of either or both aromatic rings are substituted) deposited by vapor deposition, a coating commercially known as Parylene® (available for example from V&P Scientific, Inc., San Diego, CA, USA). Parylene® is preferred not only for cell proliferation influencing properties but also for the fact that Parylene® coatings are
30 bacteria resistant, fungus resistant, transparent, have a low permeability, acid and base resistant, uniform, thin (typically 0.1 – 1 micron) and without voids even when a coated

surface includes configurations with sharp edges, points, flat surfaces, crevices or exposed internal surfaces.

The teachings of the present invention provide the possibility of providing a device useful in the field of cellular biology. A device of the present invention comprises an array of living cells held in a non-fluid matrix, the matrix configured to maintain cell viability. Generally, the matrix of a device of the present is configured to maintain cell viability. To maintain cell viability, a matrix is generally non-cytotoxic and allows transport of molecules necessary for cell survival and metabolism, such as nutrients, gases, ions and waste to and from a living cell held therein. A suitable matrix is a matrix comprising a gel, preferably a hydrogel. Preferably, the living cells are physically held in pockets in the matrix, especially free-floating in a physiological fluid in the pockets. To reduce any influence on the reactions of the cells, there is preferably substantially no bond (*e.g.*, chemical bond) between the living cells and the matrix.

In Figure 16 is depicted a device of the present invention **72**, being substantially nine living cells **74** floating inside pockets **76** inside a hydrogel matrix **78**.

In a preferred embodiment, to simplify use of the device, the array is substantially planar having an upper surface and a lower surface. In a preferred embodiment of the present invention, by substantially planar is meant that substantially all living cells of the array are arranged in a single unique plane. In another preferred embodiment of the present invention, by substantially planar is meant that substantially all the living cells are arranged in two or more planes.

To ease observation of the cells or detection of signals associated with the cells, in a preferred embodiment of the device of the present invention, one or both of the two surfaces of the device is transparent to at least one wavelength of light, including a wavelength of light of the ultraviolet spectrum, the visible spectrum or the infrared spectrum. Further, to ease observation of the cells or detection of signals associated with the cells, in a preferred embodiment of the present invention, the matrix comprises a material having an index of refraction substantially similar to that of water. By substantially similar is meant an index of refraction of less than about 1.4, less than about 1.38, less than about 1.36, less than about 1.35 or even less than about 1.34.

In a preferred embodiment of the present invention, the matrix is configured to substantially delay proliferation of living cells held therein. Configuration of a matrix so as to substantially delay proliferation of the living cells is taught in PCT IL04/00571. A preferred method of configuring a matrix to substantially delay proliferation is to make
5 at least part of the matrix from a material that has proliferation delaying properties. A preferred such material is a gel, especially a hydrogel.

In a preferred embodiment of the present invention, the matrix comprises an active entity, especially an indicator. By indicator is meant an active entity configured to indicate a cell response to a stimulus, for example a molecule that is chromatogenic
10 or fluorogenic upon exposure to some compound released by a given living cell held in the device upon exposure to some stimulus.

The unique characteristics of a device of the present invention are better understood by comparing the device to living tissue on the one hand and prior art arrays of living cells on the other hand.

15 As is known to one skilled in the art, living tissue can be considered to comprise living cells held within a matrix. Further living tissue can be maintained living for an extended period of time. It is therefore known in the art to use devices incorporating living tissues in a device for assaying cell response to stimuli. However, in living tissue the cells are not in an array; the cells are not distinct from each other making
20 identification of individual cell response difficult if not impossible especially under high throughput conditions; cells are not individually addressable so a cell of interest must be maintained under continuous observation; cells are not coplanar making visual study time-consuming due to the need for refocusing; cells are in contact with each other so that one cell may influence other neighboring cells; living tissue cannot be engineered
25 as desired to hold specific different cells in a desired spatial relationship to each other; cells in living tissue proliferate, meaning that the properties of a device including living tissue are not well-defined and change over time. Depending on the embodiment, a device of the present invention provides overcomes some or all of these disadvantages.

30 As discussed in the introduction, prior art arrays of cells all have a number of critical disadvantages. In some prior art arrays, the cells are bound to some object, whether by native adhesion or by some non-native chemical bond or attraction. Binding a cell necessarily compromises the response of cell to stimuli. In other prior art cell

arrays, there is nothing keeping cells from moving from a designated location so that there is no way to ensure that array integrity is maintained. This is exceptionally significant when cell apoptosis or other death processes occurs or when the cell array is moved. The device of the present invention provides, in contrast to prior art devices, a cell array that is robust during any cell process including cell death and during movement of the device itself.

The device of the present invention is exceptionally useful for implementing certain manipulations of living cells. For example, a device of the present invention, being substantially an ordered array of selected cells, is made in a first location such as a laboratory. The device is transported to a remote location, for example to a second laboratory, in a space vehicle or to the location of a suspected environmental disaster. A sample is contacted with the array of living cells of the device (for example, by diffusion through the matrix). The reaction of the cells is observed indicating something about the nature of the sample or of the living cells. As is clear to one skilled in the art, the device of the present invention is useful for transporting ordered cell arrays. As is clear to one skilled in the art, the device of the present invention is also useful as an indicator or assay device.

The method of the present invention comprises providing an ordered array of living cells immobilized in a matrix, the matrix configured to maintain cell viability; (b) contacting the living cells with a stimulus; and (c) detecting the response of the living cells to the stimulus.

To simplify detection or observation of the response, in a preferred embodiment of the present invention, the matrix comprises an active entity, especially an indicator, as described above. In another preferred embodiment (alone or together with an active entity of the matrix), the matrix is contacted with an active entity, preferably an active entity in solution. Generally, subsequent to contacting an active entity with the matrix, it is necessary to wait a period of time in order to allow the active entity to reach the proximity of the cells, for example by diffusion.

Although there are many methods for detecting the response of the living cells to a stimulus, the preferred method involves the detection of light. By detection of light is meant detection of emitted light (for example, light emitted by an indicator or light emitted by a given cell). By detection of light is also meant detection of light that has

interacted with a given cell, the vicinity of a given cell, or an indicator in the vicinity of a given cell where the light is indicative of the cell response. Clearly such detecting includes detection of fluorescence, differential polarization and optical inspection of a cell.

5 A device of the present invention is a preferred device for implementing the method of the present invention. That said, the present invention also provides a general method for producing an ordered array of living cells useful, for example, in implementing the method of the present invention using a multiwell plate of the present invention. The method of producing an ordered array of living cells, comprises: (a)
10 providing a multiwell plate of the present invention, (b) placing a suspension of a plurality of living cells in a gellable fluid in at least one well provided with picowells; (c) causing the living cells to settle into the picowells so as to be held in respective picowells; and (d) gelling the gellable fluid so as to make a gel cover, trapping the living cells between the picowells and the gel cover. In a preferred embodiment, the
15 picowells are made of a material comprising a gel, preferably a hydrogel.

Generally, causing the cells to settle into the wells includes applying a force to the cells, typical forces including gravitation, centrifugal forces, forces resulting from the impact of photons on the cells (*e.g.*, laser tweezers, application of a non-focussed laser (see, for example, P.A.L.M. Microlaser Technologies AG, Bernried, Germany)),
20 or forces resulting from a pressure wave (such as produced by an ultrasonic transponder). Most preferred is the application of centrifugal force, *vide infra*.

As stated above, once the cells have settled in a respective picowell, it is preferred to gel the gellable fluid so as to form a cover on the picowells. As a result, the cells are held snugly, without excessive physical stress, between the inside of a
25 respective picowell and the surrounding gel cover. An appropriate method of gelling a gellable fluid is dependent on the nature of the gellable fluid and includes methods such as heating the gellable fluid, cooling the gellable fluid, irradiating the gellable fluid, illuminating the gellable fluid, contacting the gellable fluid with a gelling reagent and waiting a period of time for the gellable fluid to gel.

30 It is generally preferred to use a gellable fluid that forms a hydrogel upon gelling. Exceptionally suitable gellable fluids are fluids that comprise a material selected from

the group consisting of agars, agaroses, gelatins, low melting temperature agaroses, alginates, room-temperature Ca^{2+} -inducible alginates and polysaccharides.

It is preferred that a gellable fluid that gels under conditions that are conducive for cell survival be used for implementing the teachings of the present invention. One preferred gellable fluid is an alginate solution. Alginates are biologically compatible polysaccharide proteins that are fluid at low calcium ion concentrations (*e.g.*, $[\text{Ca}^{2+}] < 1 \mu\text{M}$) but gel upon exposure to higher concentrations of calcium ions (*e.g.*, $[\text{Ca}^{2+}] = 20 \text{ mM}$). An exceptionally suitable alginate for implementing the teachings of the present invention is sodium alginate and may be purchased, for example, from Pronova Biopolymers (Drammen, Norway) as Protanal LF120 1% in water or Protanal LF200 1% in water.

Another preferred gellable solution is a solution of low melting temperature agarose. Low melting temperature agaroses are biologically compatible gels that before gelling are fluid at temperatures that do not harm living cells (*e.g.*, 20°C), gel at low temperatures that do not harm living cells (*e.g.*, 4°C) and remain stable until well-above temperatures used for studying living cells (40°C). An exceptionally suitable agarose for implementing the teachings of the present invention that may be purchased, for example, from Cambrex Bio Science Rockland Inc. (Rockland, ME, USA) is HGS-LMP Agarose (catalogue nr. 50221).

It is important to note that for maximal utility of a produced device, it is desirable to ensure that substantially each pocket holds no more than one living cell or no more than a predetermined number of cells. This is most easily achieved by ensuring that the picowells of the picowell array are juxtaposed and that a given picowell is of a size to accommodate no more than one living cell (or the predetermined number of cells). Generally when a suspension of cells with a number of cells greater than the number of picowells is placed in proximity of juxtaposed picowells and the cells allowed to settle, all picowells will be filled but there will be excess cells "stacked" on top of cells held in picowells. A preferred method for preventing such "stacking" is that the suspension brought in proximity of the picowells has approximately a predetermined number of cells. It has been found that when the number of cells in the suspension is approximately equal to the number of picowells (or the product of the number of picowells and the number of cells desired to be held in each picowell), there is

- 50 -

substantially the desired number of cells per picowell, with only minimal stacking of cells on top of already fully occupied picowells.

In a preferred embodiment of the method of the present invention, the gellable fluid includes an active entity, especially an indicator, as described above. In such a way, the active entity becomes an integral part of the matrix of a device produced
5 according to the method of the present invention.

In some embodiments of the method of the present invention, some or all of the wells of a multiwell plate are provided with picowells. In some embodiments, all of the picowells of the multiwell plate are substantially the same. In some embodiments, all of
10 the picowells in one well are substantially the same, but are different from picowells in other wells. In some embodiments, in a given well, there are found two different types of picowells. By different is meant, for example, have a different size or comprise different active ingredients.

In a specific example, a 96-well glass plate **52** of the present invention is
15 provided, Figure 17. In plate **52**, all wells **44** are provided with a plurality of integrally formed hexagonally-packed knife-edged hexagonal picowells. The picowells in each one of wells **44** of rows A, B, C and D have a diameter of 10 micron while the plurality of picowells **18** in each one of wells **44** of rows in rows E, F, G and H have a diameter of 20 micron.

20 Using an automatic liquid dispensing robot (Automated Microplate Pipetting Systems - Precision™ XS Microplate Sample Processor, Bio-Tek Instruments, Vinooski, VT, USA) different suspensions of living cells in liquid solutions of a gellable solution, comprising a low melting temperature agarose (*e.g.*, HGS-LMP Agarose of Cambrex Bio Science Rockland Inc., Rockland, ME, USA) are added to the
25 wells of each row. The cells suspended in the solution dispensed in rows A, B, C and D are peripheral lymphocytes having a diameter of about 5 to 7 microns. The cells suspended in the solution dispensed in rows E, F, G and H are Jurkat T cell line cells having a diameter of about 15-20. The number of cells dispensed in each well **44** is about 95% of the number of picowells in that well. In addition, the solutions dispensed
30 into a given well **44** also include active reagents:

- 51 -

a. in the solutions dispensed in rows A, B, E and F a first indicator for measuring mitochondrial membrane potential is dispensed (100nM tetramethyl rhodamine methyl ester);

5 b. in the solutions dispense in rows C, D, G and H a second indicator for measuring intracellular levels of reactive oxygen species is dispensed (10 μ M dichlorodihydro fluorescein diacetate);

Once all cell suspensions are dispensed, 96-well plate 52 is transferred to a centrifuge provided with a cooling unit and centrifuged so as to cause dispensed cells to settle into picowells. After sufficient time for cell settling, centrifugation is stopped and
10 the cooling unit is activated so as to bring the temperature of the gel to about 4°C and thus initiate gelling. When sufficient time has passed for complete gelling of the gellable fluid, the multiwell plate is used for examining metabolism during cell death. To rows B, D, F and H a third active agent (50 μ M solution of hydrogen peroxide as apoptosis inducer) is added to each one of wells 44 of rows B, D, F and H. During the
15 time it takes for the third active agent to diffuse through the gel cover, plate 52 is transferred to an observation unit configured to detect the intensity of color developed in each picowell. Comparison of the development of color in wells of row B (with A as control) shows the development of mitochondrial membrane potential as a result of apoptosis of peripheral lymphocytes. Comparison of the development of color in wells
20 of row C (with D as control) shows the development of intracellular levels of reactive oxygen species as a result of apoptosis of peripheral lymphocytes. Comparison of the development of color in wells of row F (with E as control) shows the development of mitochondrial membrane potential as a result of apoptosis of Jurkat T cells. Comparison of the development of color in wells of row H (with G as control) shows
25 the development of intracellular levels of reactive oxygen species as a result of apoptosis of Jurkat T cells.

Since each of the cells is held in a respective picowell, no cell is lost during the apoptosis process. Since the cells are held in a substantially planar array of cells, the exact number of cells and distribution of reactions is accurately monitored.

30

It is appreciated that certain features of the invention, which are, for clarity, described in the context of separate embodiments, may also be provided in combination in a single embodiment. Conversely, various features of the invention, which are, for brevity, described in the context of a single embodiment, may also be provided
5 separately or in any suitable subcombination. Although the invention has been described in conjunction with specific embodiments thereof, it is evident that many alternatives, modifications and variations will be apparent to those skilled in the art. Accordingly, the present invention is intended to embrace all such alternatives, modifications and variations that fall within the spirit and broad scope of the appended claims.

10

All publications, patents and patent applications mentioned in this specification are herein incorporated in their entirety by reference into the specification, to the same extent as if each individual publication, patent or patent application was specifically and individually indicated to be incorporated herein by reference. In addition, citation or
15 identification of any reference in this application shall not be construed as an admission that such reference is available as prior art to the present invention.

WHAT IS CLAIMED IS

1. A multiwell plate comprising a plurality of wells wherein at the bottom surface of at least one well of said plurality of wells is a plurality of picowells.
2. The plate of claim 1, having a footprint of a standard multiwell plate.
3. The plate of claim 1, wherein said plurality of wells comprises $6n$ wells arranged in a $2n \times 3n$ array, where n is an integer greater than 0.
4. The plate of claim 1, wherein wells of said plurality of wells are rectangularly packed.
5. The plate of claim 3, wherein said plurality of wells is selected from the group consisting of 6, 24, 96, 384 and 1536 wells.
6. The plate of claim 3, wherein said plurality of wells is 96 wells.
7. The plate of claim 3, wherein said plurality of wells is 384 wells.
8. The plate of claim 1, wherein said plurality of picowells comprises individually addressable picowells.
9. The plate of claim 1, wherein the bottoms of all picowells in a said well of the plate are substantially coplanar.
10. The plate of claim 1, wherein the bottoms of all picowells of the plate are substantially coplanar.
11. The plate of claim 1, wherein picowells of said plurality of picowells are juxtaposed.

12. The plate of claim 11, wherein the interwell area between two said picowells is less than about 0.35 the sum of the areas of said two picowells.

13. The plate of claim 11, wherein the interwell area between two said picowells is less than about 0.25 the sum of the areas of said two picowells.

14. The plate of claim 11, wherein the interwell area between two said picowells is less than about 0.15 the sum of the areas of said two picowells.

15. The plate of claim 11, wherein the interwell area between two said picowells is less than about 0.10 the sum of the areas of said two picowells.

16. The plate of claim 11, wherein the interwell area between two said picowells is less than about 0.06 the sum of the areas of said two picowells.

17. The plate of claim 11, wherein a rim of a said picowell is substantially knife-edged.

18. The plate of claim 1, wherein said plurality of picowells comprises picowells having dimensions of less than about 200 microns.

19. The plate of claim 18, wherein the dimensions of said picowells are less than about 100 microns.

20. The plate of claim 18, wherein the dimensions of said picowells are less than about 50 microns.

21. The plate of claim 18, wherein the dimensions of said picowells are less than about 25 microns.

22. The plate of claim 18, wherein the dimensions of said picowells are less than about 10 microns.

23. The plate of claim 1, wherein said plurality of picowells comprises picowells configured to hold no more than one living cell of a certain size.

24. The plate of claim 1, wherein said plurality of picowells comprises picowells configured to hold no more than a predetermined number of living cells of a certain size.

25. The plate of claim 1, wherein picowells of said plurality of picowells comprise enclosures of dimensions such that substantially an entire cell of a certain size is containable within a said enclosure, each said enclosure having an opening, said opening defined by a first cross section of a size allowing passage of a cell of a certain size.

26. The plate of claim 25, wherein the volume of a said enclosure is less than about 1×10^{-11} liter.

27. The plate of claim 25, wherein the volume of a said enclosure is less than about 1×10^{-12} liter.

28. The plate of claim 25, wherein the volume of a said enclosure is less than about 1×10^{-13} liter.

29. The plate of claim 25, wherein the volume of a said enclosure is less than about 1×10^{-14} liter.

30. The plate of claim 25, wherein the volume of a said enclosure is less than about 1×10^{-15} liter.

31. The plate of claim 25, wherein the area of a said first cross section is less than about 40000 micron^2 .

32. The plate of claim 25, wherein the area of a said first cross section is less than about 10000 micron².

33. The plate of claim 25, wherein the area of a said first cross section is less than about 2500 micron².

34. The plate of claim 25, wherein the area of a said first cross section is less than about 625 micron².

35. The plate of claim 25, wherein the area of a said first cross section is less than about 100 micron².

36. The plate of claim 25, a said enclosure having dimensions so as to contain no more than one cell of said certain size at any one time.

37. The plate of claim 25, a said enclosure having dimensions so as to contain no more than a predetermined number of cells of said certain size at any one time.

38. The plate of claim 1, said plurality of picowells comprising picowells, wherein all picowells of the plate are substantially identical in size.

39. The plate of claim 1, wherein a first said well includes a first said plurality of picowells and a second said well includes a second said plurality of picowells, wherein said first plurality of picowells and said second plurality of picowells are substantially different.

40. The plate of claim 39, wherein the size of picowells of said first plurality of picowells and the size of picowells of said second plurality of picowells are substantially different.

- 57 -

41. The plate of claim 1, comprising a material selected from the group consisting of ceramics, elastomers, epoxies, glasses, glass-ceramics, metals, plastics, polycarbonates, polydimethylsiloxane, polyethyleneterephthalate glycol, polymers, polymethyl methacrylate, polystyrene, polyurethane, polyvinyl chloride, rubber, silicon, silicon oxide and silicon rubber.

42. The plate of claim 1, said bottom surface comprising a material selected from the group consisting of ceramics, elastomers, epoxies, glasses, glass-ceramics, metals, plastics, polycarbonates, polydimethylsiloxane, polyethyleneterephthalate glycol, polymers, polymethyl methacrylate, polystyrene, polyurethane, polyvinyl chloride, rubber, silicon, silicon oxide and silicon rubber.

43. The plate of claim 1, wherein the walls of wells of said plurality of wells are integrally formed with said bottom surface.

44. The plate of claim 1, further comprising at least one distinct well-wall component attached to said bottom surface.

45. The plate of claim 44, said distinct well-wall component comprising a material selected from the group consisting of ceramics, elastomers, epoxies, glasses, glass-ceramics, metals, plastics, polycarbonates, polydimethylsiloxane, polyethyleneterephthalate glycol, polymers, polymethyl methacrylate, polystyrene, polyurethane, polyvinyl chloride, rubber, silicon, silicon oxide and silicon rubber.

46. The plate of claim 1, wherein said plurality of picowells are integrally formed with said bottom surface.

47. The plate of claim 1, further comprising at least one distinct picowell-bearing component bearing said plurality of picowells attached to said bottom surface of said one well.

48. The method of claim 47, wherein said picowell-bearing component is a carrier comprising a plurality of picowells disposed on a surface.

49. The plate of claim 47, said distinct picowell-bearing component made of a material selected from the group consisting of reversibly deformable materials and irreversibly deformable materials.

50. The plate of claim 47, wherein said distinct picowell-bearing component is made of a material selected from the group consisting of waxes, hydrocarbon waxes, crystalline waxes, paraffins, ceramics, elastomers, epoxies, glasses, glass-ceramics, metals, plastics, polycarbonates, polydimethylsiloxane, polyethyleneterephthalate glycol, polymers, polymethyl methacrylate, polystyrene, polyurethane, polyvinyl chloride, rubber, silicon, silicon oxide and silicon rubber.

51. The plate of claim 1, further comprising at least one distinct picowell-bearing component bearing said plurality of picowells resting within said one well.

52. The method of claim 51, wherein said picowell-bearing component is a carrier comprising a plurality of picowells disposed on a surface.

53. The plate of claim 51, wherein said distinct picowell-bearing component is made of a material selected from the group consisting of reversibly deformable materials and irreversibly deformable materials.

54. The plate of claim 51, wherein said distinct picowell-bearing component is made of a material selected from the group consisting of gels, hydrogels, waxes, hydrocarbon waxes, crystalline waxes, paraffins, ceramics, elastomers, epoxies, glasses, glass-ceramics, metals, plastics, polycarbonates, polydimethylsiloxane, polyethyleneterephthalate glycol, polymers, polymethyl methacrylate, polystyrene, polyurethane, polyvinyl chloride, rubber, silicon, silicon oxide and silicon rubber.

- 59 -

55. The plate of claim 51, wherein said picowell-bearing component comprises a gel.

56. The device of claim 55, wherein said gel is substantially transparent.

57. The device of claim 55, wherein said gel is a hydrogel.

58. The device of claim 55, wherein the water content of said gel is greater than about 80% by weight.

59. The device of claim 55, wherein the water content of said gel is greater than about 92% by weight.

60. The device of claim 55, wherein the water content of said gel is greater than about 95% by weight.

61. The device of claim 55, wherein the water content of said gel is greater than about 97% by weight.

62. The device of claim 55, wherein the water content of said gel is greater than about 98% by weight.

63. The device of claim 55, wherein said gel is made of a material selected from the group consisting of agar gels, agarose gels, gelatins, low melting temperature agarose gels, alginate gels, room-temperature Ca^{2+} -induced alginate gels and polysaccharide gels.

64. The device of claim 55, wherein said gel comprises an active entity.

65. The device of claim 64, wherein said active entity is selected from the group consisting of antibodies, antigens, biological materials, chemical materials, chromatogenic compounds, drugs, enzymes, fluorescent probes, immunogenes,

- 60 -

indicators, ligands, nucleic acids, nutrients, peptides, physiological media, proteins, receptors, selective toxins and toxins.

66. The plate of claim 1, said plurality of picowells comprising picowells, said picowells having a bottom surface made of a first material and borders made of a second material, said second material being substantially different from said first material.

67. The plate of claim 66, wherein said first material is substantially the material from which said bottom of said well is made.

68. The plate of claim 66, wherein said bottom surface of said picowell is substantially said bottom surface of said well.

69. The plate of claim 66, wherein said second material is fixed photoresist material.

70. The plate of claim 1, wherein said plurality of picowells comprises picowells having an inside surface configured to delay adhesion of living cells thereto.

71. The plate of claim 70, wherein said inside surface comprises an adhesion-delaying material.

72. The plate of claim 70, wherein said inside surface is coated with said adhesion-delaying material.

73. The plate of claim 1, said plurality of picowells comprising picowells, the bottom of said picowells substantially having an index of refraction similar to that of water.

74. The plate of claim 73, wherein said index of refraction is less than about 1.4.

75. The plate of claim 73, wherein said index of refraction is less than about 1.38.
76. The plate of claim 73, wherein said index of refraction is less than about 1.36.
77. The plate of claim 73, wherein said index of refraction is less than about 1.35.
78. The plate of claim 73, wherein said index of refraction is less than about 1.34.
79. The plate of claim 1, said plurality of picowells comprising picowells, said picowells having an inner surface coated with a layer of a material.
80. The plate of claim 79, said material selected from the group consisting of gels, hydrogels, polydimethylsiloxane, elastomers, polymerized para-xylylene molecules, polymerized derivatives of para-xylylene molecules, rubber and silicon rubber.
81. The plate of claim 1, further comprising a gel cover covering said plurality of picowells.
82. The plate of claim 1, wherein said plurality of picowells covers substantially the entire said bottom surface of said well.
83. The plate of claim 1, further comprising at least one additional feature functionally associated with said plurality of picowells.
84. The plate of claim 83, wherein said additional feature comprises a microfluidic feature functionally associated with said plurality of picowells.

- 62 -

85. The plate of claim 84, wherein said feature is selected from the group consisting of channels, coupling elements, drains, fluid channels, fluid reservoirs, input ports, membranes, microreactors, microvalves, output ports, passages, plumbing routes, protruberances, pumps, transport channels and valves.

86. The plate of claim 83, wherein said feature is selected from the group consisting of light sources, magnetizable elements, optical components, optical fibers, optical filters, protuberances, fiducial points and walls.

87. The plate of claim 1, further comprising a cover slip, said cover slip and said plurality of picowells configured so as to allow said cover slip to rest above said plurality of picowells substantially in parallel to said bottom surface.

88. A method of making a multiwell plate of claim 1, comprising:

(a) contacting a precursor material with a template including a negative of features of the plate so as to create said features in said precursor material, said features including said plurality of picowells;

(b) fixing said features in said precursor material so as to fashion an incipient plate; and

(c) processing said incipient plate so as to fashion the plate.

89. The method of claim 88, wherein said template comprises a material selected from the groups consisting of reversibly deformable materials, irreversibly deformable materials, ceramics, epoxies, glasses, glass-ceramics, metals, plastics, polycarbonates, polydimethylsiloxane, polyethylenterephtalate glycol, polymers, polymethyl methacrylate, paraffins, polystyrene, polyurethanes, polyvinyl chloride, silicon, silicon oxide, silicon rubbers and wax.

90. The method of claim 88, wherein said fixing comprises a method selected from the group consisting of heating said precursor material, cooling said precursor material, polymerizing said precursor material, cross-linking said precursor material, curing said precursor material, irradiating said precursor material, illuminating

- 63 -

said precursor material, gelling said precursor material, exposing said precursor material to a fixative and waiting a period of time.

91. The method of claim 88, said features further comprising at least one feature selected from the group of features consisting of channels, coupling elements, drains, fluid channels, fluid reservoirs, input ports, microreactors, microvalves, passages, optical components, optical filters, output ports, plumbing routes, protruberances, pumps, transport channels, valves, walls, patial walls and fiducial points.

92. The method of claim 88, said features further comprising said plurality of wells.

93. The method of claim 88, further comprising:

(d) prior to (a), placing said precursor material in a well of a multiwell plate.

94. The method of claim 88, further comprising:

(d) subsequent to (b), attaching walls of said plurality of wells to said incipient plate.

95. The method of claim 94, wherein said attaching comprises using an adhesive to attach said walls to said incipient plate.

96. The method of claim 94, wherein said attaching comprises using a surface treatment to attach said walls to said incipient plate.

97. The method of claim 96, wherein said surface treatment is a plasma treatment.

98. The method of claim 88, wherein said precursor material includes a irreversibly deformable precursor material and said fixing said features comprises separating said template from said precursor material.

- 64 -

99. The method of claim 98, wherein said irreversibly deformable precursor material is selected from the group consisting of wax, paraffins, plastics and polymers.

100. The method of claim 88, wherein said precursor material comprises an reversibly deformable precursor material.

101. The method of claim 100, wherein said reversibly deformable precursor material is selected from the group consisting of gellable fluids, polymerizable materials, powders, fluids and thermoplastic materials.

102. The method of claim 101, wherein said reversibly deformable precursor material includes a thermoplastic material at plastic temperature and wherein said fixing said features comprises cooling said thermoplastic material.

103. The method of claim 101, wherein said reversibly deformable precursor material includes a polymerizable material and wherein said fixing said features comprises polymerizing said polymerizable material.

104. The method of claim 103, wherein said polymerizable material is selected from the group consisting of monomer solutions, crosslinkable polymers, vulcanizable polymers, polymerizable fluids and thermosetting resins.

105. The method of claim 104, wherein said polymerizable material includes a polydimethylsiloxane precursor mixture and said fixing said features comprises polymerizing said polydimethylsiloxane precursor mixture so as to produce polydimethylsiloxane.

106. The method of claim 104, wherein said polymerizable material includes urethane and said fixing said features comprises polymerizing said urethane to produce polyurethane.

107. The method of claim 101, wherein said reversibly deformable precursor material includes a gellable fluid and wherein said fixing said features comprises gelling said gellable fluid.

108. The method of claim 107, wherein said gelling said gellable fluid comprises an action selected from the group consisting of heating said gellable fluid, cooling said gellable fluid, irradiating said gellable fluid, illuminating said gellable fluid, contacting said gellable fluid with a gelling reagent and waiting a period of time for said gellable fluid to gel.

109. The method of claim 107, wherein said gellable fluid comprises a solution including a material selected from the group consisting of agars, agaroses, gelatins, low melting temperature agaroses, alginates, proteins, protein polysaccharides, Ca^{2+} -inducible alginates and polysaccharides.

110. The method of claim 107, wherein said gellable fluid includes an alginate solution and said gelling said gellable fluid comprises contacting said gellable fluid with a gelling reagent.

111. The method of claim 110, wherein said gelling reagent comprises Ca^{2+} ions.

112. The method of claim 107, wherein said gellable fluid includes a low melting temperature agarose solution and said gelling said gellable fluid comprises cooling said gellable fluid.

113. The method of claim 88, wherein said processing said incipient plate comprises coating an inside surface of picowells of said plurality of picowells with a layer of a coating material.

114. The method of claim 113, wherein said coating said inside surface comprises:

- 66 -

(i) applying a precursor fluid with said inside surface of said picowells;
and

(ii) solidifying said precursor fluid so as to form said layer of said coating material.

115. The method of claim 114, wherein said solidifying comprises a method selected from the group consisting of heating said precursor fluid, cooling said precursor fluid, polymerizing said precursor fluid, cross-linking said precursor fluid, curing said precursor fluid, irradiating said precursor fluid, illuminating said precursor fluid, gelling said precursor fluid, exposing said precursor fluid to a fixative and waiting a period of time.

116. The method of claim 113, wherein said coating said inside surface comprises:

(i) depositing a vapor of said coating material onto said inside surface of said picowells thereby forming said layer of said coating material.

117. The method of claim 113, wherein said coating said inside surface comprises:

(i) depositing a vapor of a coating precursor material onto said inside surface of said picowells; and

(ii) solidifying said coating precursor material thereby forming said layer of said coating material.

118. The method of claim 117, wherein said solidifying said coating precursor material comprises a method selected from heating said coating precursor material, cooling said coating precursor material, polymerizing said coating precursor material, cross-linking said coating precursor material, curing said coating precursor material, irradiating said coating precursor material, illuminating said coating precursor material, gelling said coating precursor material, exposing said coating precursor material to a fixative and waiting a period of time.

- 67 -

119. The method of claim 117, wherein said vapor is a vapor of para-xylylene molecules or derivatives thereof and said layer of said coating material comprises a layer of polymerized said para-xylylene molecules or derivatives thereof.

120. A method of making a multiwell plate of claim 1, comprising:

- (a) placing a photoresist material on a precursor plate; and
- (b) fixing a plurality of picowells in said photoresist material.

121. The method of claim 120 wherein said fixing comprises irradiating said photoresist material through a mask.

122. The method of claim 120, wherein said precursor plate comprises a material selected from the group consisting of ceramics, epoxies, glasses, glass-ceramics, metals, plastics, polycarbonates, polydimethylsiloxane, polymers, polyethyleneterephthalate glycol, polymethyl methacrylate, polystyrene, polyurethanes, polyvinyl chloride, silicon and silicon oxide.

123. The method of claim 120, wherein said precursor plate comprises a multiwell plate.

124. The method of claim 120, further comprising:

- (c) subsequent to (b), attaching walls of wells to said precursor plate.

125. The method of claim 120, further comprising:

(c) subsequent to (b), coating an inside surface of picowells of said plurality of picowells with a layer of a coating material.

126. A method of making a multiwell plate of claim 1, comprising placing a picowell-bearing component on a precursor plate.

127. The method of claim 126, further comprising attaching said picowell-bearing component to said precursor plate

128. The method of claim 127, wherein said attaching comprises using an adhesive to attach said picowell-bearing component to said precursor plate.

129. The method of claim 127, wherein said attaching comprises a surface treatment to attach said picowell-bearing component to said precursor plate.

130. The method of claim 129, wherein said surface treatment is a plasma treatment.

131. The method of claim 126, wherein said precursor plate comprises a multiwell plate.

132. The method of claim 126, further comprising attaching walls of wells to said precursor plate.

133. The method of claim 126, wherein said picowell-bearing component is a carrier comprising a plurality of picowells disposed on a surface.

134. The method of claim 126, further comprising, subsequent to said attaching of said picowell-bearing component, coating an inside surface of picowells of said picowell-bearing component with a layer of a coating material.

135. A device comprising an array of living cells held in a non-fluid matrix, said matrix configured to maintain cell viability.

136. The device of claim 135, wherein said living cells are physically held in pockets in said matrix.

- 69 -

137. The device of claim 135, wherein there is substantially no bond between said living cells and said matrix.

138. The device of claim 135, wherein said array is substantially planar having an upper surface and a lower surface.

139. The device of claim 138, wherein at least one said surfaces is transparent to at least one wavelength of light.

140. The device of claim 139, wherein a said transparent surface is said upper surface.

141. The device of claim 139, wherein a said transparent surface is said lower surface.

142. The device of claim 139, wherein said at least one wavelength of light is in the ultraviolet spectrum.

143. The device of claim 139, wherein said at least one wavelength of light is in the visible spectrum.

144. The device of claim 139, wherein said at least one wavelength of light is in the infrared spectrum.

145. The device of claim 135, said matrix comprising a material having an index of refraction substantially similar to that of water.

146. The device of claim 145, said matrix comprising a material having an index of refraction less than about 1.4.

147. The device of claim 145, said matrix comprising a material having an index of refraction less than about 1.38.

148. The device of claim 145, said matrix comprising a material having an index of refraction less than about 1.36.

149. The device of claim 145, said matrix comprising a material having an index of refraction less than about 1.35.

150. The device of claim 145, said matrix comprising a material having an index of refraction less than about 1.34.

151. The device of claim 135, said matrix configured to substantially delay proliferation of living cells held therein.

152. The device of claim 135, said matrix made of a material comprising a gel.

153. The device of claim 135, said matrix comprising an active entity.

154. The device of claim 153, said active entity comprising an indicator.

155. The method of claim 153, said active entity comprising an indicator, said indicator configured to indicate a cell response to a stimulus.

156. The method of claim 155, wherein said cell response is a release of a second active entity.

157. A method for handling living cells, comprising:

(a) providing an ordered array of living cells immobilized in a non-fluid matrix, said matrix configured to maintain cell viability;

(b) contacting said living cells with a stimulus; and

(c) detecting a response of said cells to said stimulus.

158. The method of claim 157, said matrix comprising an active entity

159. The method of claim 158, said active entity comprising an indicator.
160. The method of claim 159, said active entity comprising an indicator, said indicator configured to indicate a cell response to a stimulus.
161. The method of claim 160, wherein said cell response is a release of a second active entity.
162. The method of claim 157, wherein said detecting comprises contacting an active entity with said matrix.
163. The method of claim 162, further comprising waiting a period of time so as to allow said active entity to reach proximity with said cells.
164. The method of claim 162, said active entity comprising an indicator.
165. The method of claim 162, said active entity comprising an indicator, said indicator configured to indicate a cell response to a stimulus.
166. The method of claim 165, wherein said cell response is a release of a second active entity.
167. The method of claim 157, wherein said detecting comprises detecting emitted light.
168. The method of claim 157, wherein said detecting comprises detecting light.
169. A method of producing an ordered array of living cells in a non-fluid matrix, comprising:

- 72 -

(a) providing a multiwell plate provided with a plurality of wells, said multiwell plate including a plurality of picowells at the bottom of at least one said well, said plurality of picowells including picowells;

(b) placing a suspension of a plurality of living cells in a gellable fluid in said at least one well;

(c) causing said living cells to settle into said picowells so as to be held in respective picowells; and

(d) gelling said gellable fluid so as to make a gel cover, trapping said living cells between said picowells and said gel cover.

170. The method of claim 169, wherein said picowells are made of a material comprising a gel.

171. The method of claim 169, wherein said causing said cells to settle comprises applying a force to said cells.

172. The method of claim 171, wherein said force is a force resulting from the impact of photons.

173. The method of claim 171, wherein said force is a force resulting from a pressure wave.

174. The method of claim 171, wherein said force is gravitation.

175. The method of claim 171, wherein said force is a centrifugal force.

176. The method of claim 169, wherein

(e) prior to (d), ensuring that substantially each picowell holds no more than one living cell.

177. The method of claim 169, wherein said gelling said gellable fluid comprises an action selected from the group consisting of heating said gellable fluid,

cooling said gellable fluid, irradiating said gellable fluid, illuminating said gellable fluid, contacting said gellable fluid with a gelling reagent and waiting a period of time for said gellable fluid to gel.

178. The method of claim 169, wherein said gellable fluid is selected so as to form a hydrogel upon said gelling.

179. The method of claim 169, wherein said gellable fluid is selected from solutions containing a material selected from the group consisting of agars, agaroses, gelatins, low melting temperature agaroses, alginates, room-temperature Ca^{2+} -inducible alginates and polysaccharides.

180. The method of claim 179, wherein said gellable fluid is an alginate and said gelling said gellable fluid comprises contacting said gellable fluid with a gelling reagent.

181. The method of claim 179, wherein said gellable fluid is a low melting temperature agarose and said gelling said gellable fluid comprises cooling said gellable fluid.

182. The method of claim 169, wherein said gellable fluid comprises an active entity.

183. The method of claim 169, said active entity comprising an indicator.

184. The method of claim 183, said active entity comprising an indicator, said indicator configured to indicate a cell response to a stimulus.

185. The method of claim 184, wherein said cell response is a release of a second active entity.

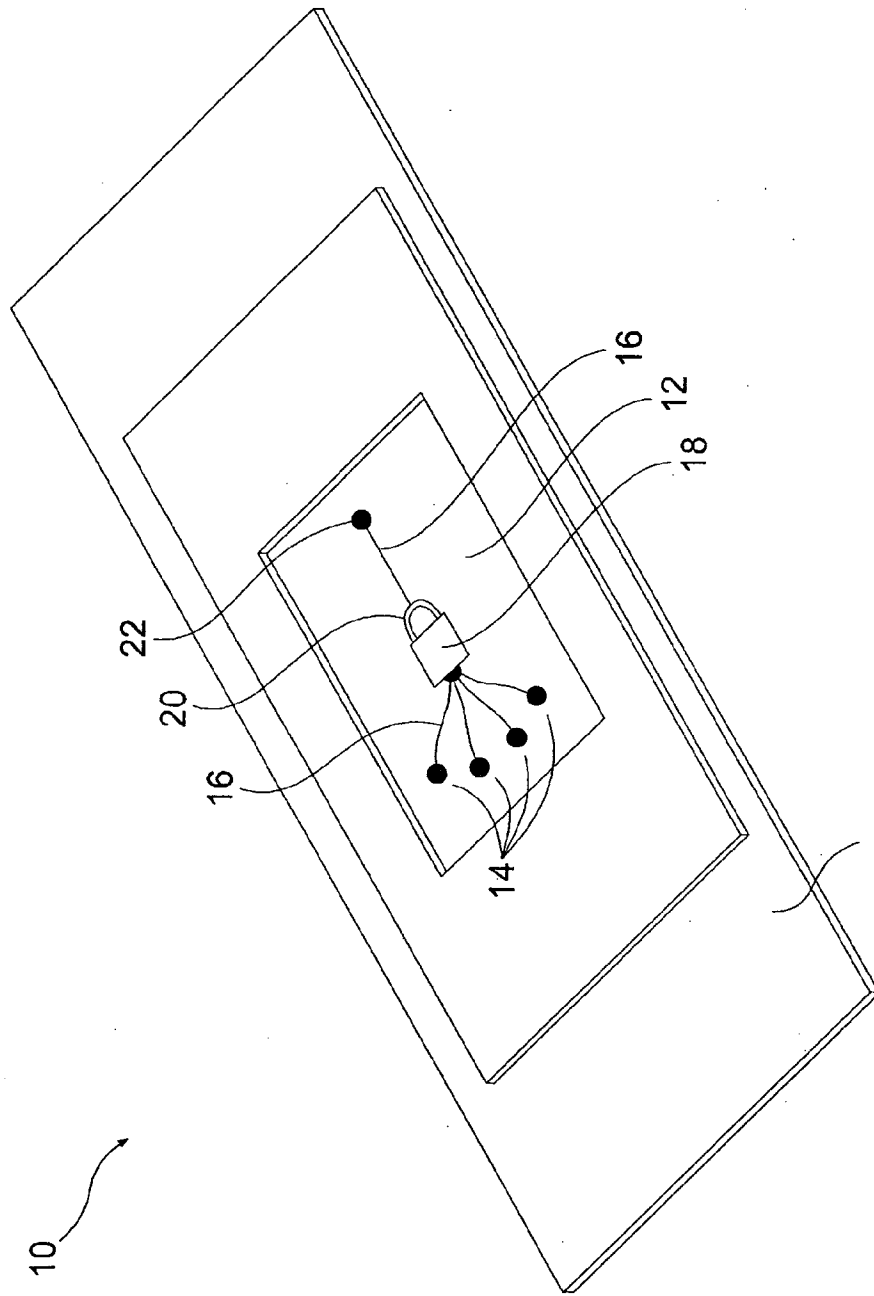

24

FIG. 1 (PRIOR ART)

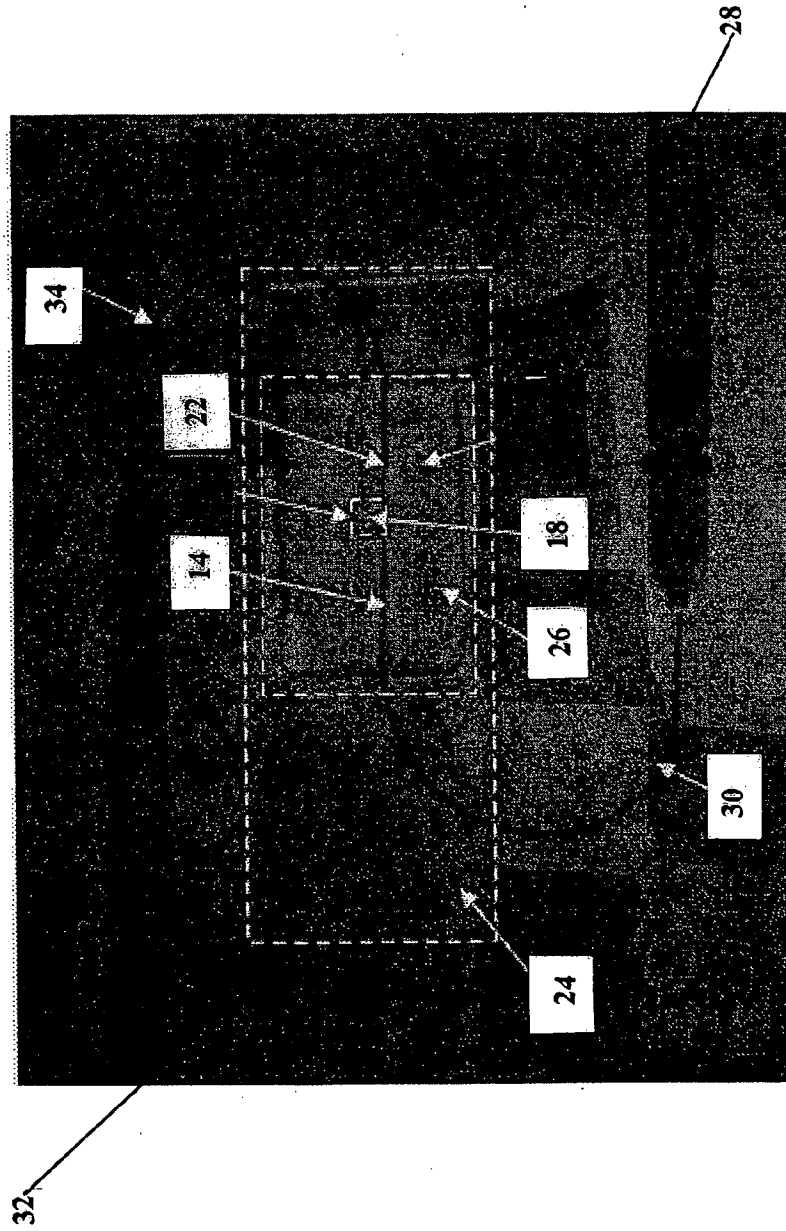

FIG. 2 (PRIOR ART)

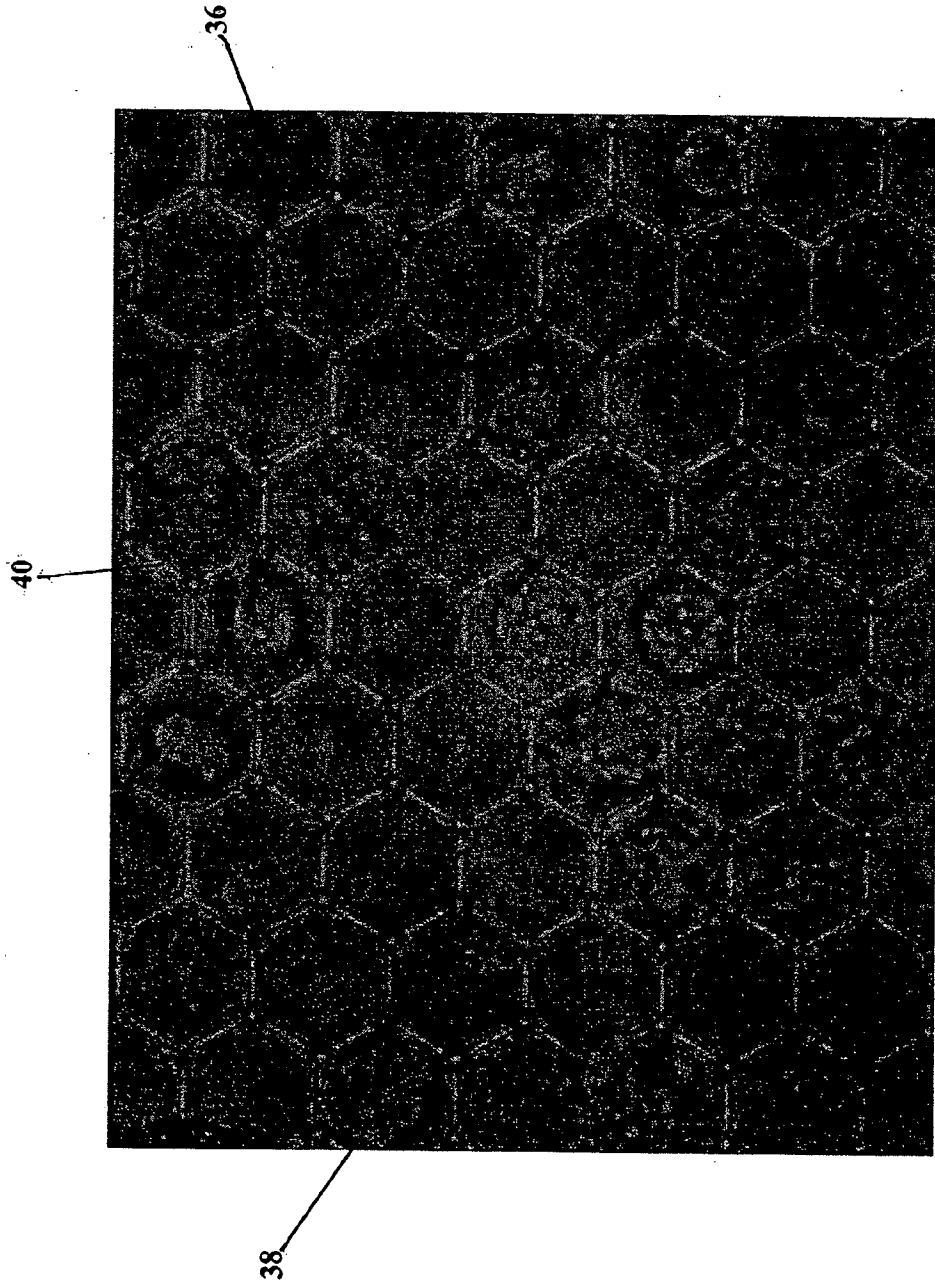

FIG. 3 (PRIOR ART)

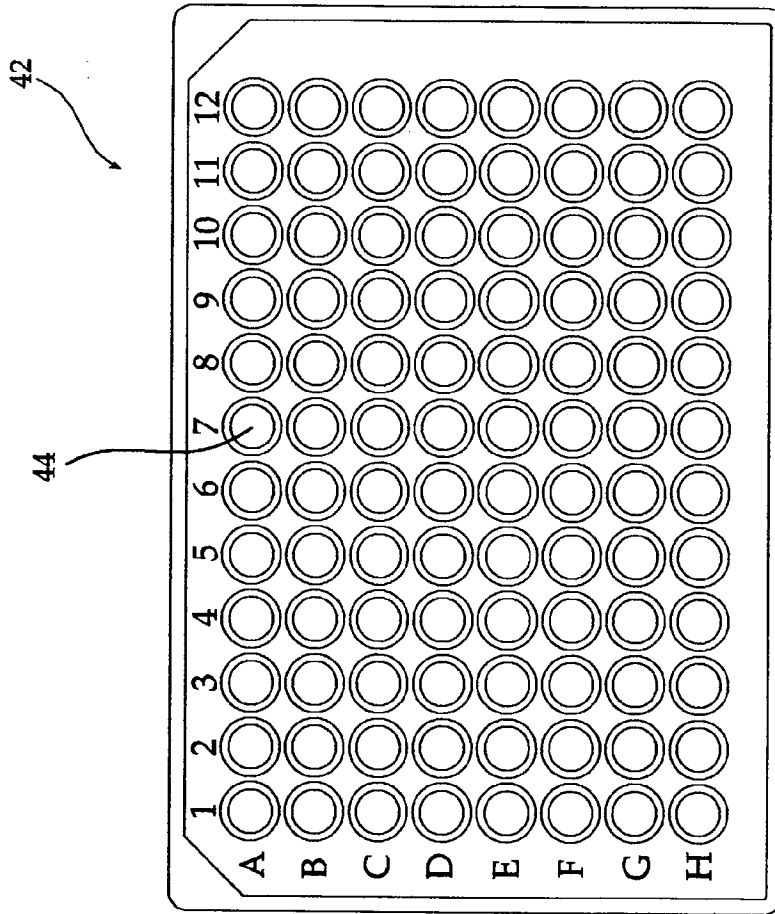

FIG. 4 (PRIOR ART)

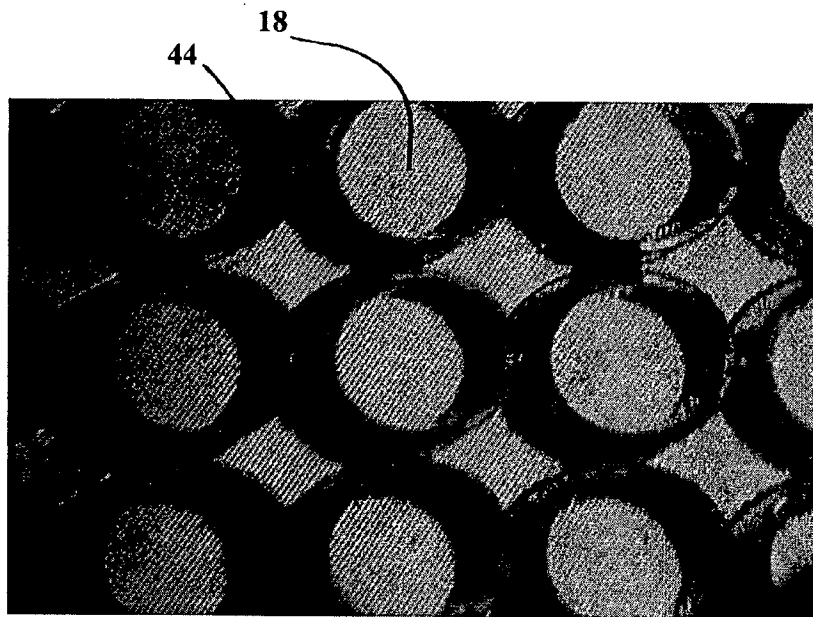

FIG. 5A

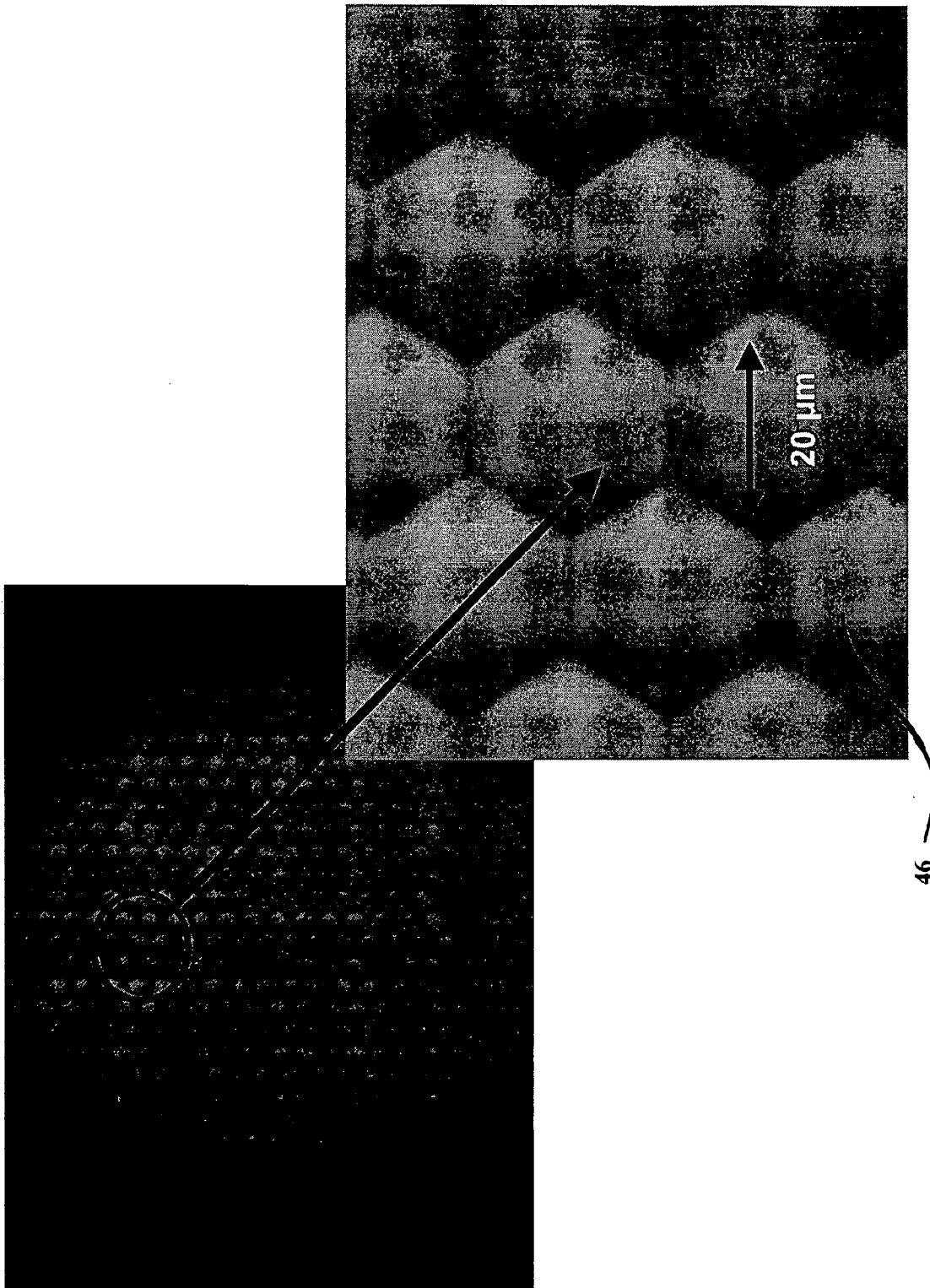

FIG. 5B

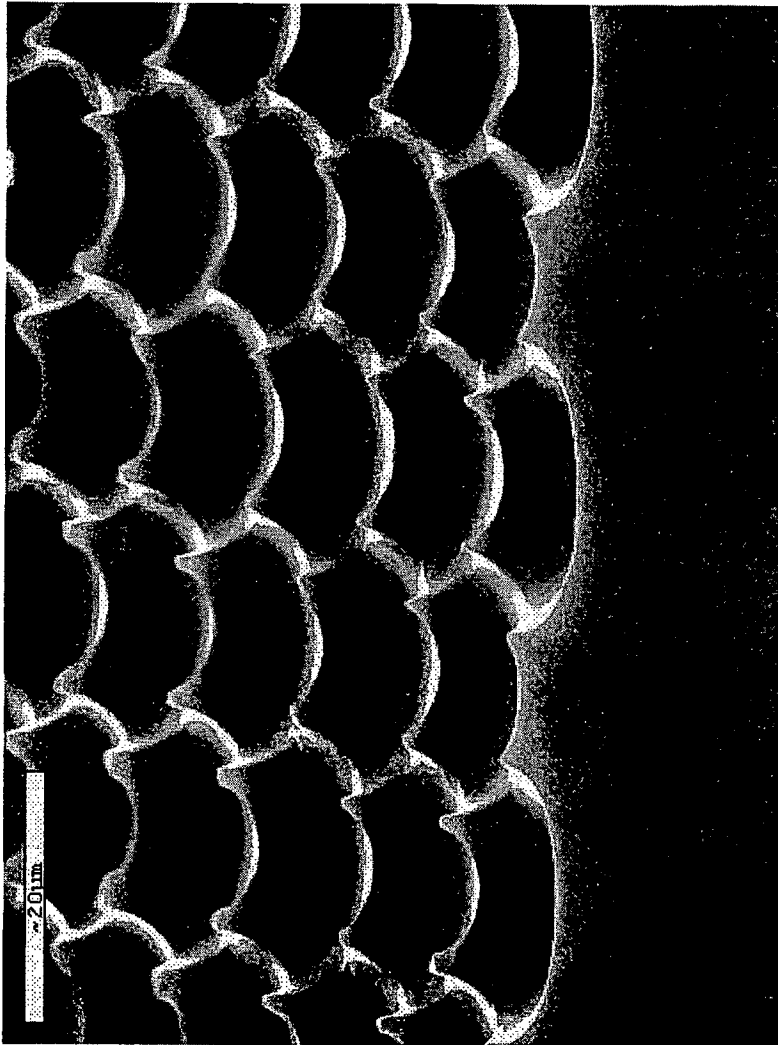

FIG. 6

8/20

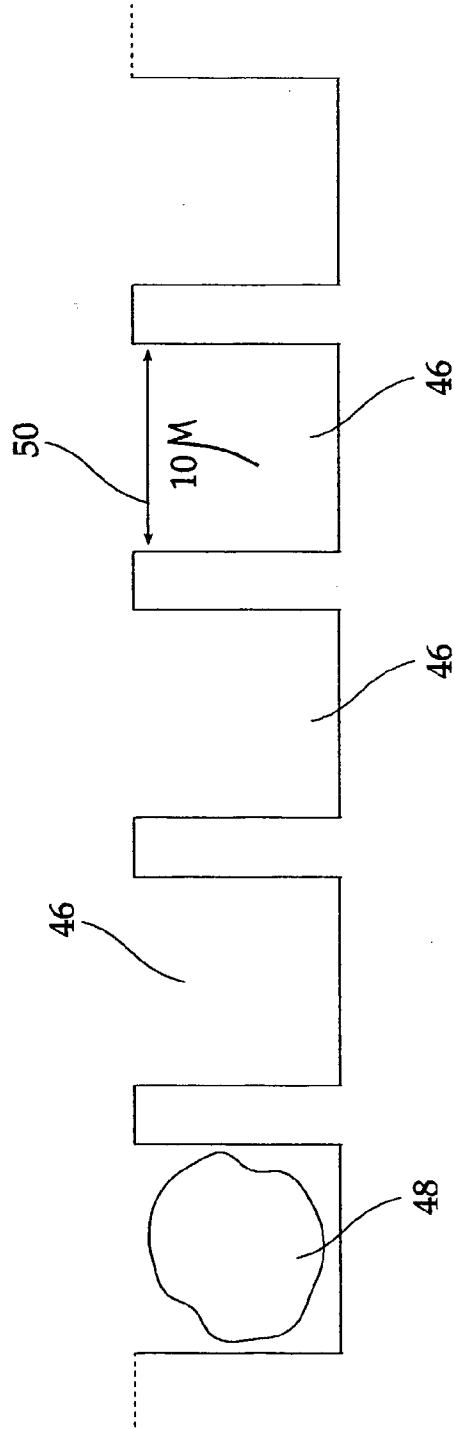

FIG. 7

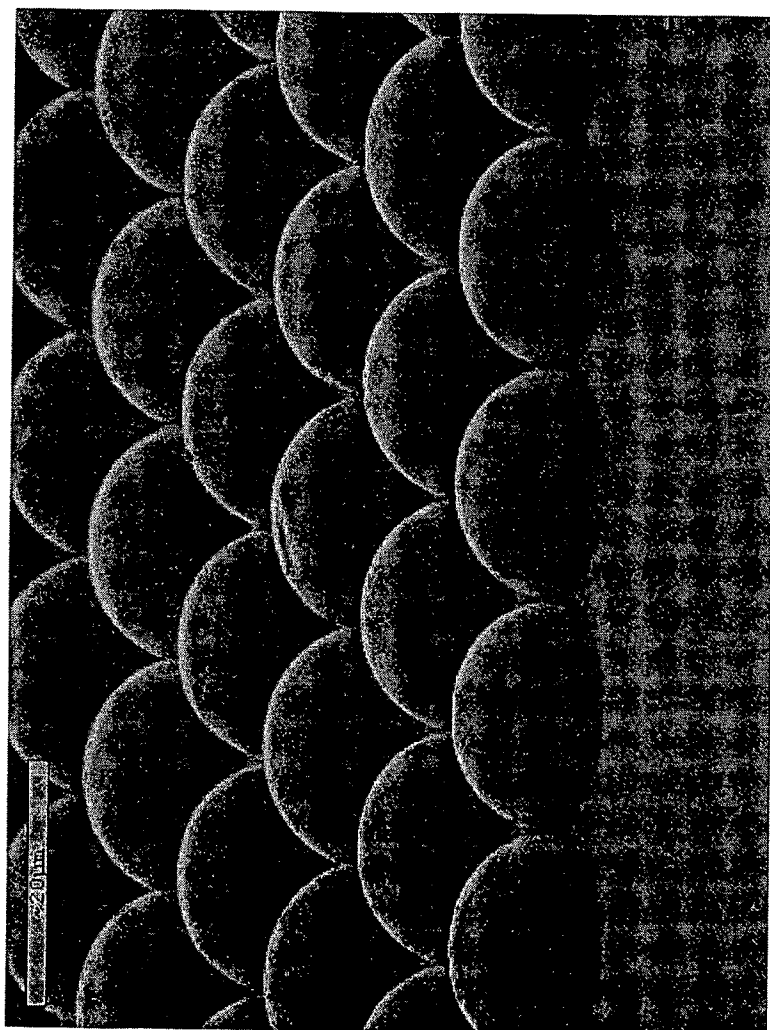

FIG. 8

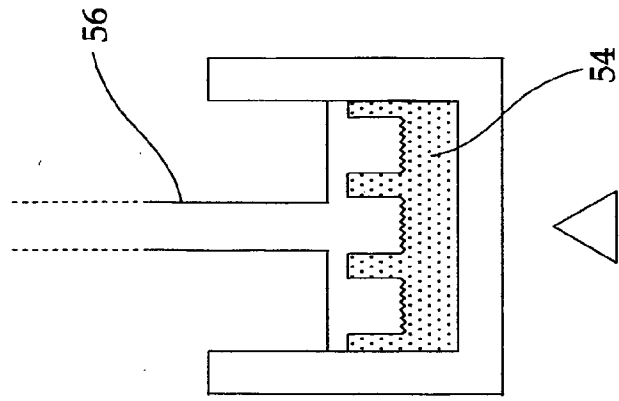

FIG. 9C

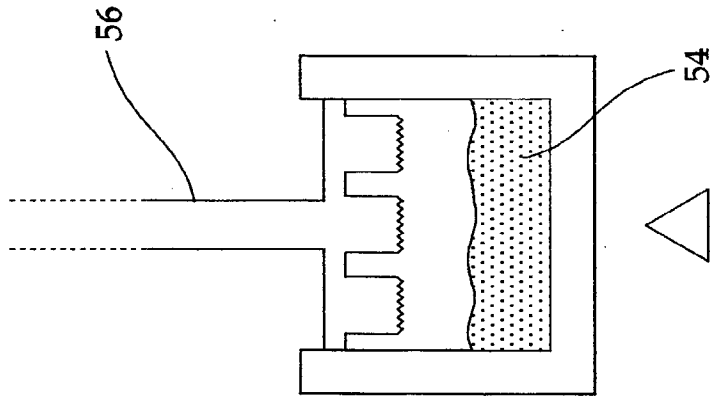

FIG. 9B

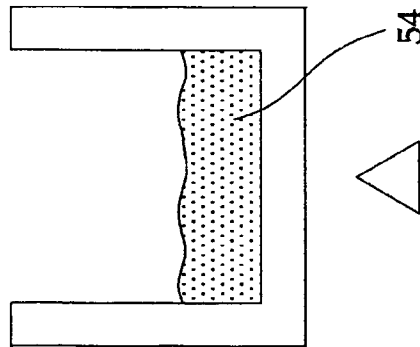

FIG. 9A

11/20

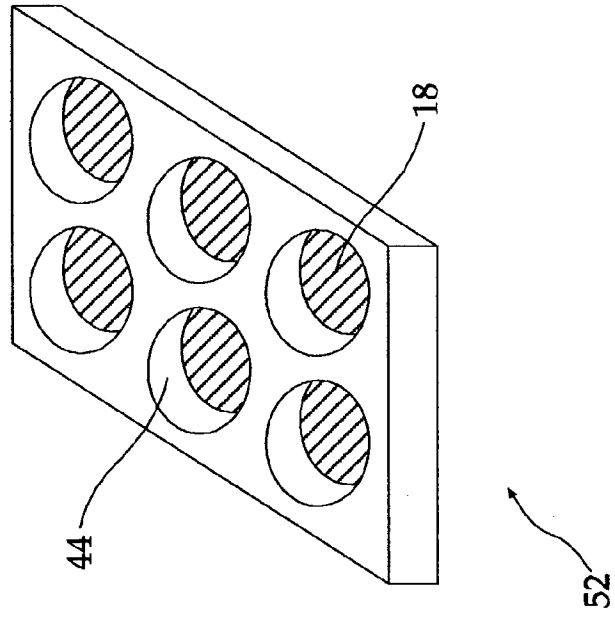

FIG. 9F

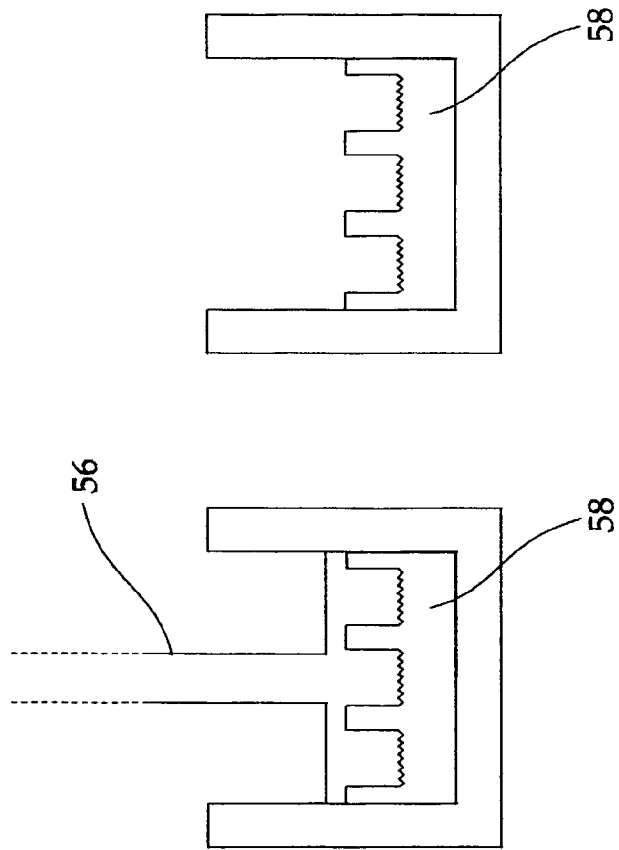

FIG. 9E

FIG. 9D

12/20

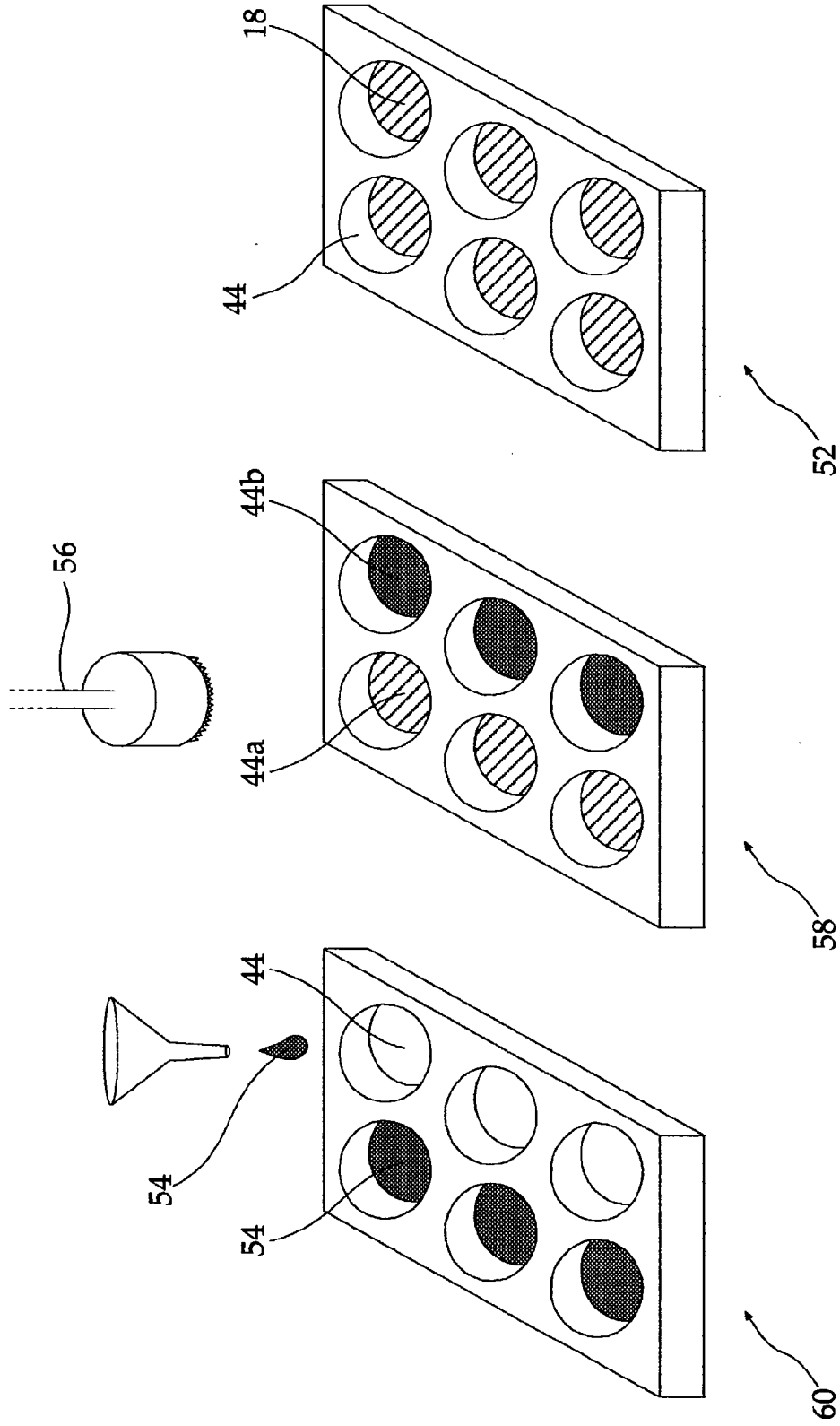

FIG. 10C

FIG. 10B

FIG. 10A

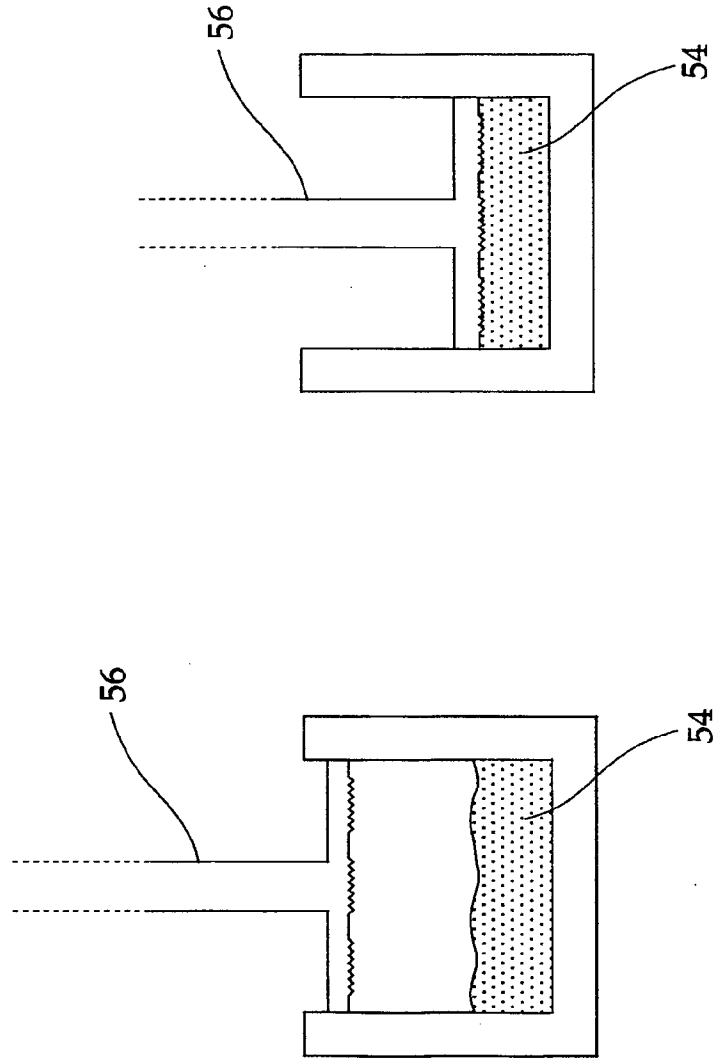

FIG.11B

FIG.11A

14/20

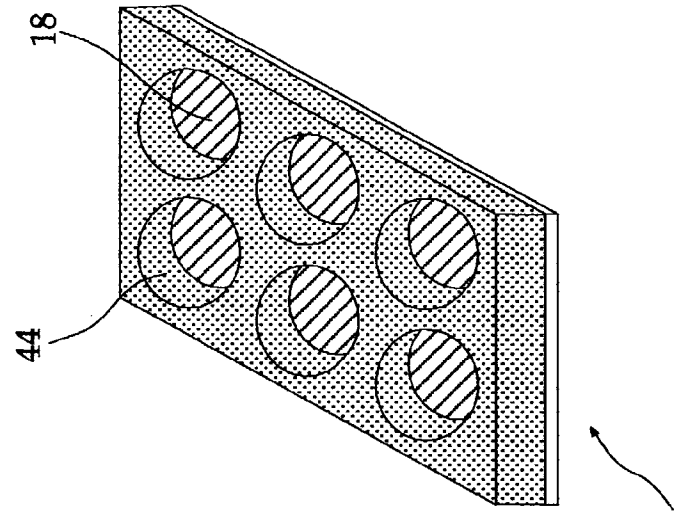

FIG. 11E

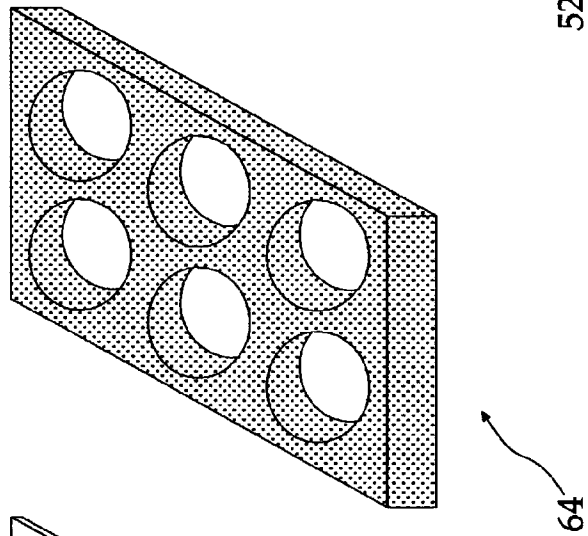

FIG. 11D

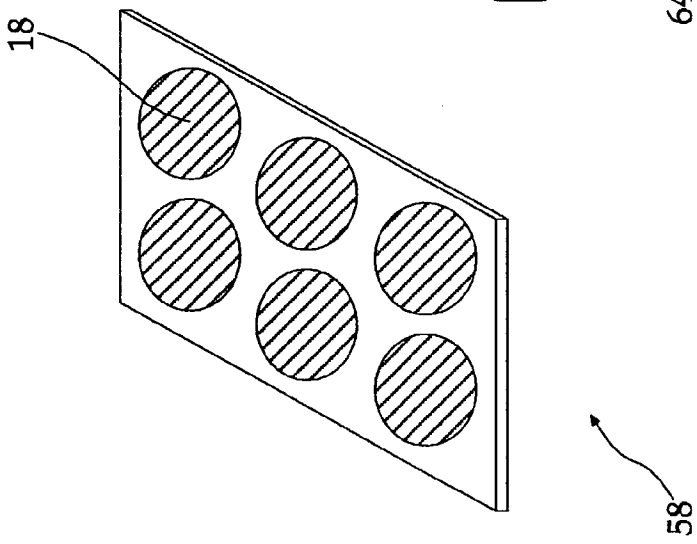

FIG. 11C

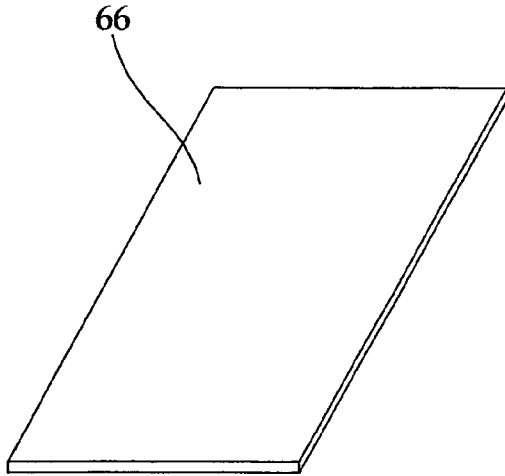

FIG. 12A

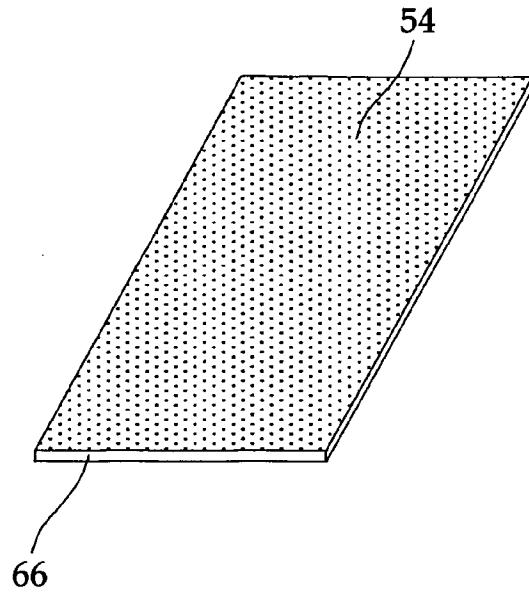

FIG. 12B

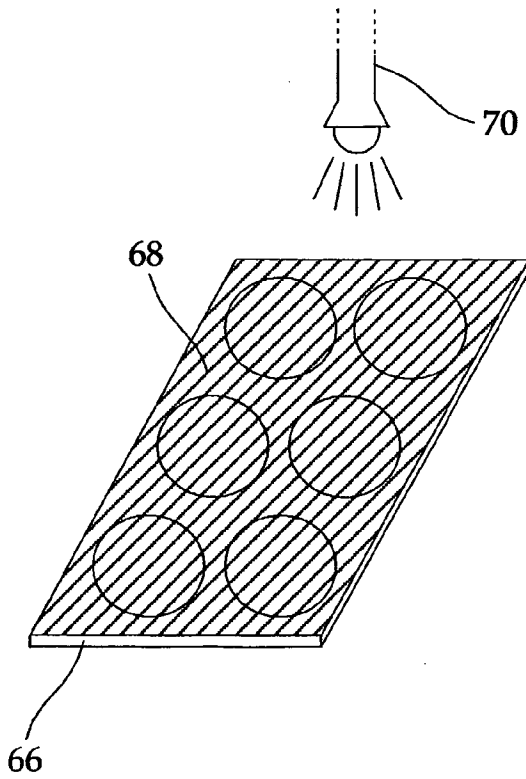

FIG. 12C

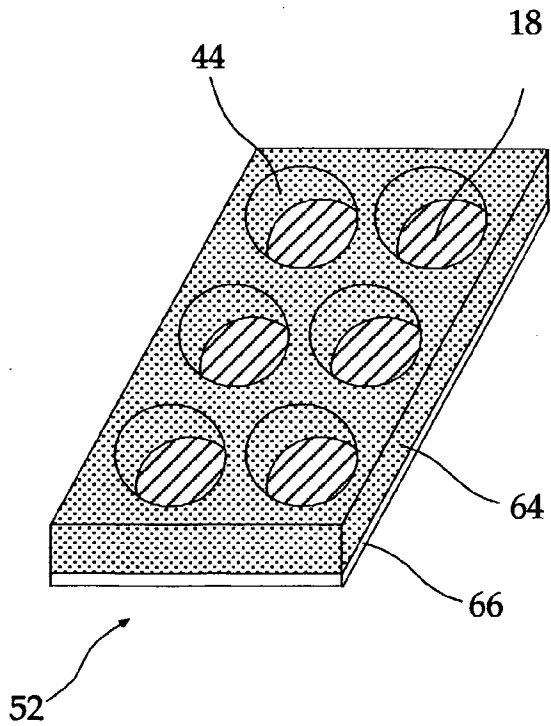

FIG. 12D

16/20

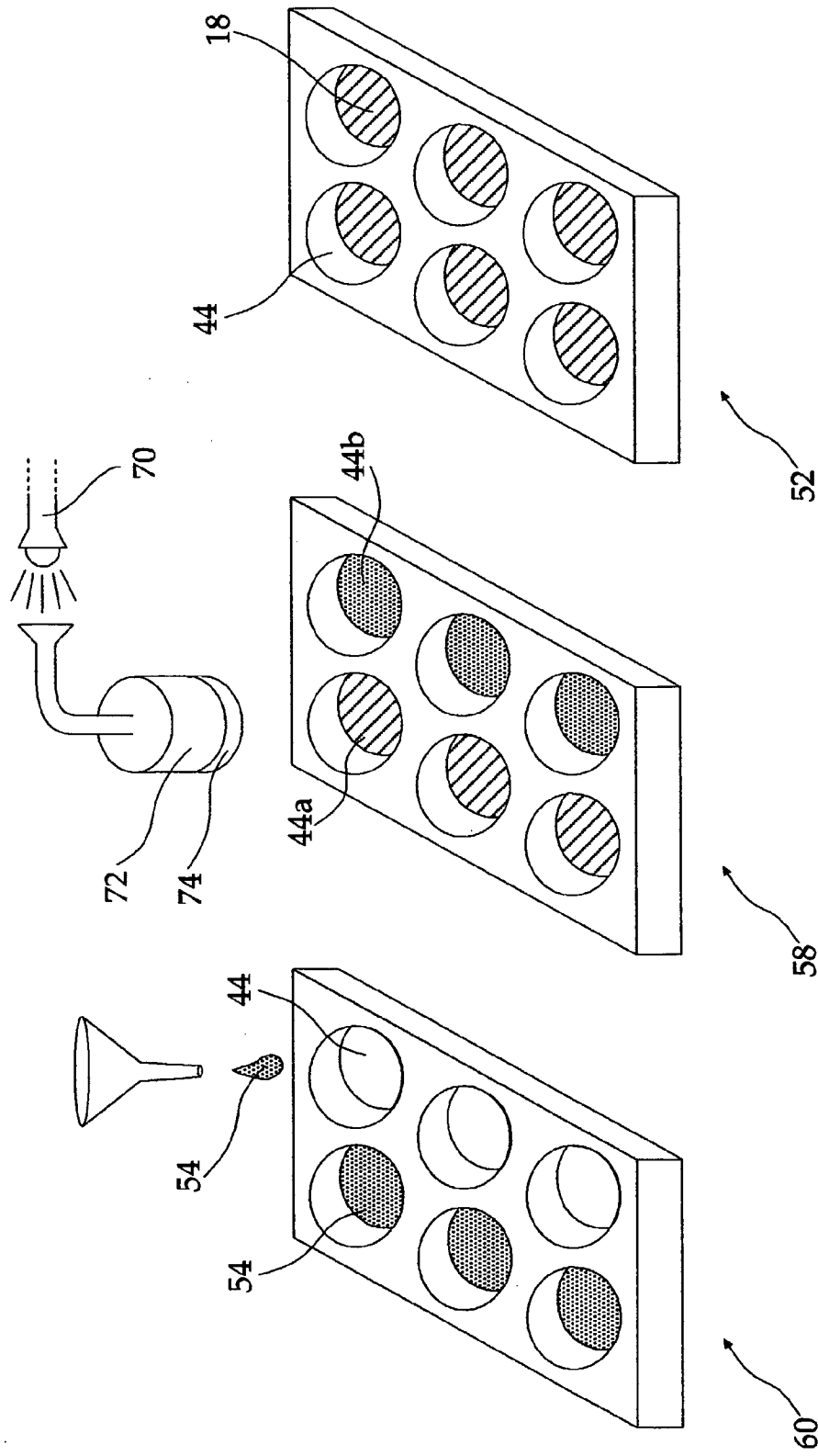

FIG. 13C

FIG. 13B

FIG. 13A

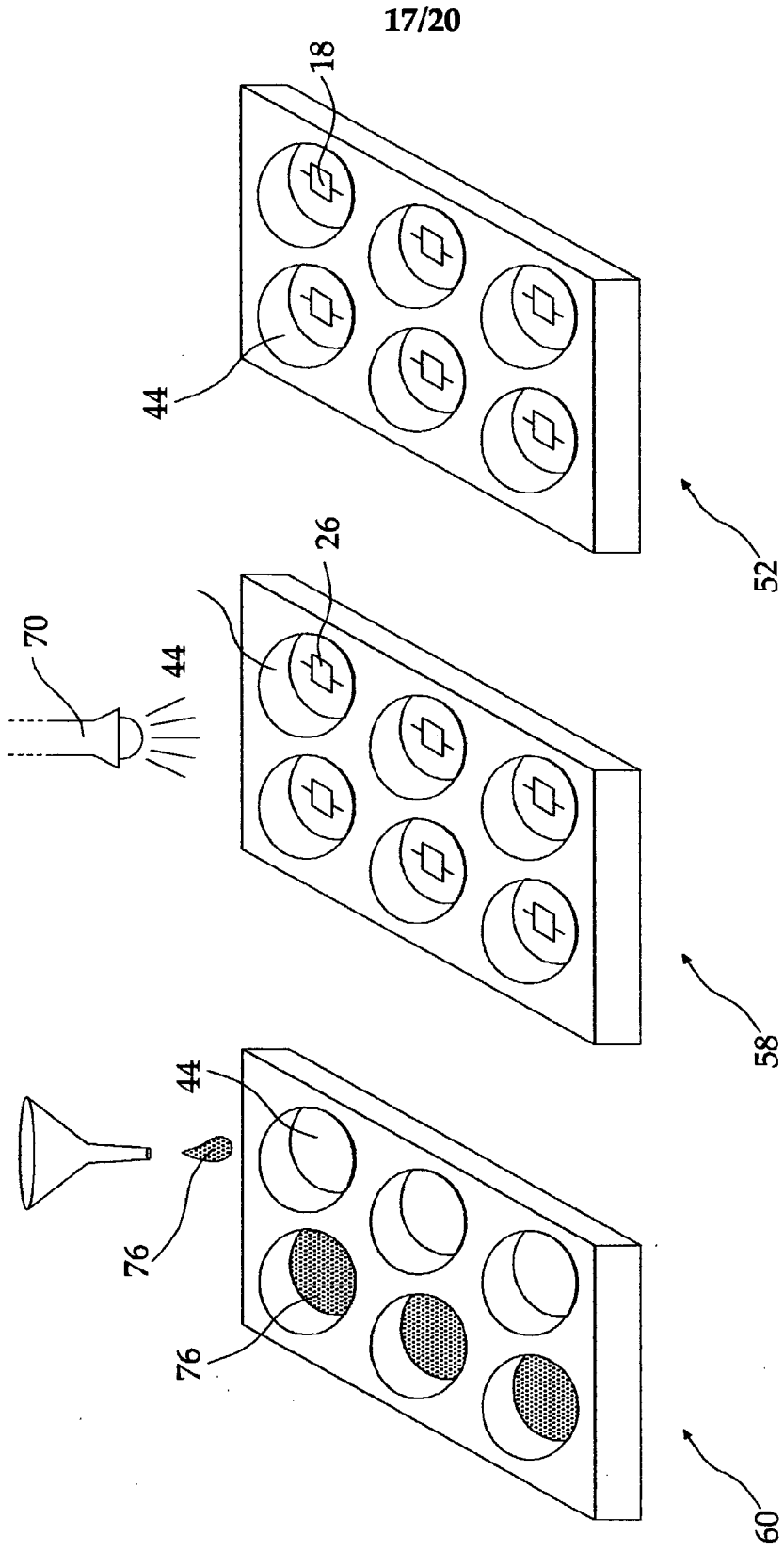

FIG. 14C

FIG. 14B

FIG. 14A

18/20

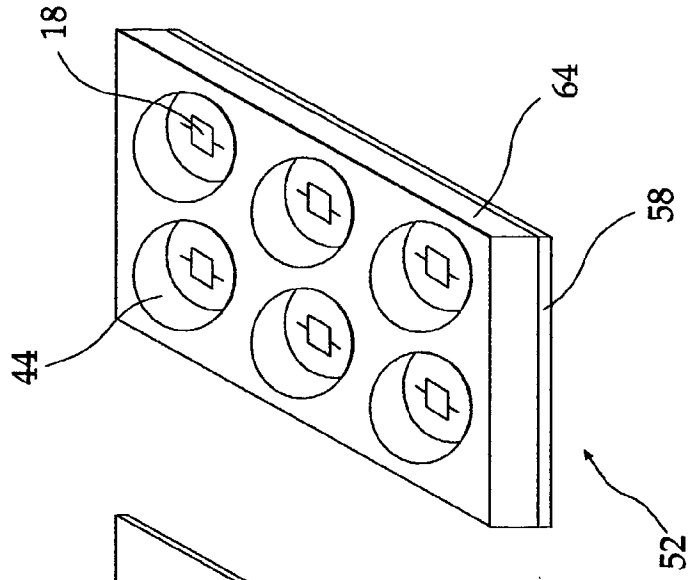

FIG. 15C

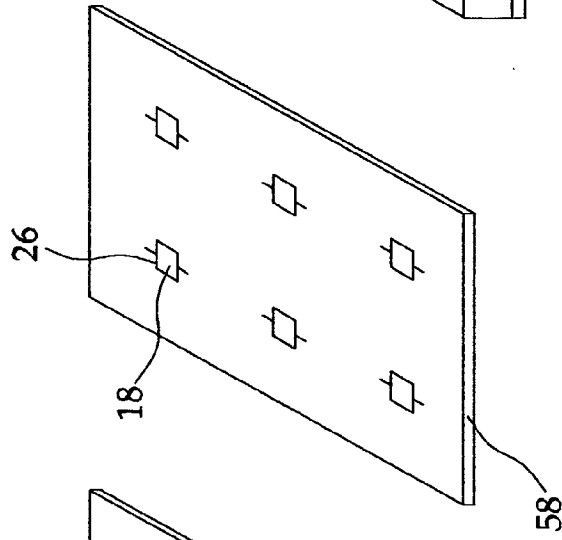

FIG. 15B

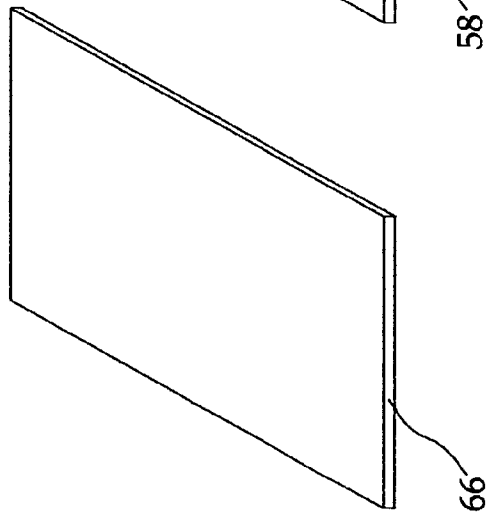

FIG. 15A

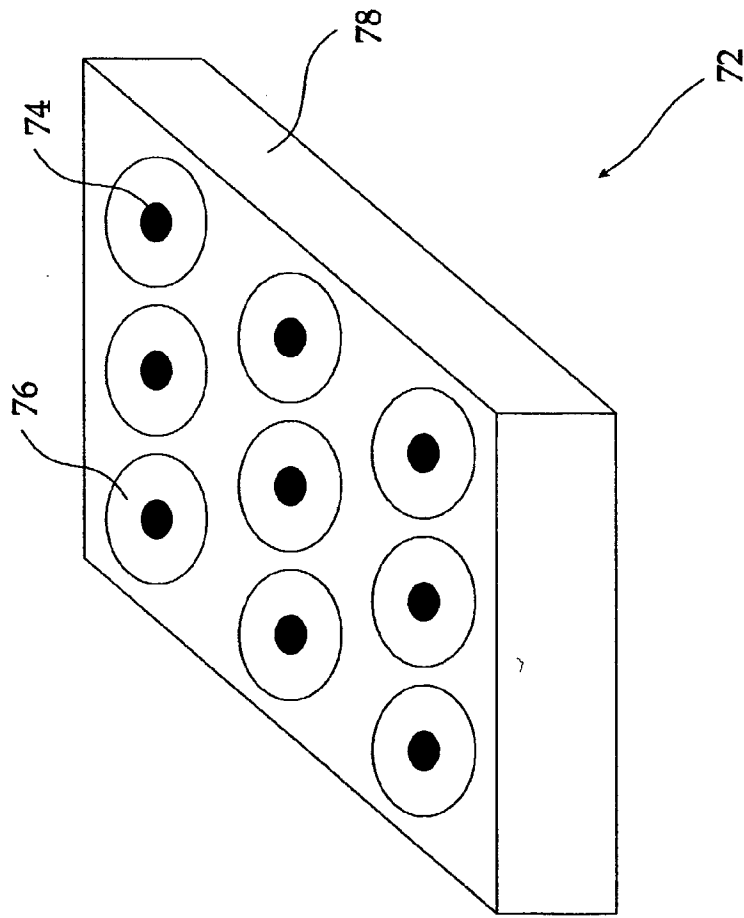

FIG. 16

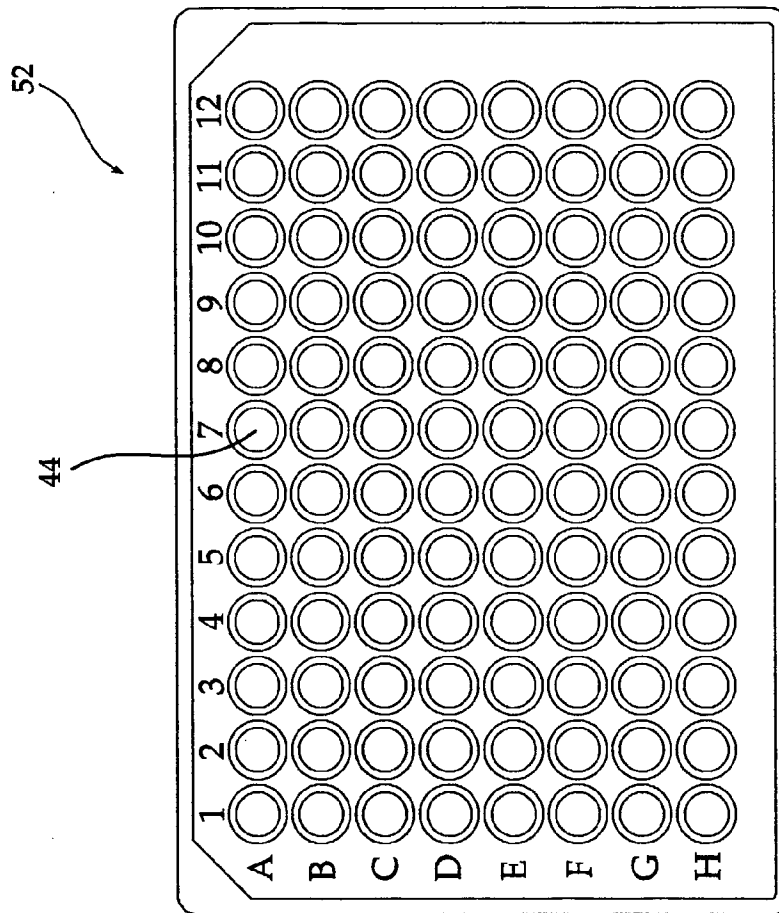

FIG. 17

(19) World Intellectual Property Organization
International Bureau



(43) International Publication Date
27 January 2005 (27.01.2005)

PCT

(10) International Publication Number
WO 2005/007796 A3

(51) International Patent Classification⁷: C12M 3/00, (74) Agent: G.E. EHRLICH (1995) LTD.; 11 Menachem Begun Street, 52 521 Ramat Gan (IL).

(21) International Application Number: PCT/IL2004/000661

(81) Designated States (unless otherwise indicated, for every kind of national protection available): AE, AG, AL, AM, AT, AU, AZ, BA, BB, BG, BR, BW, BY, BZ, CA, CH, CN, CO, CR, CU, CZ, DE, DK, DM, DZ, EC, EE, EG, ES, FI, GB, GD, GE, GH, GM, HR, HU, ID, IL, IN, IS, JP, KE, KG, KP, KR, KZ, LC, LK, LR, LS, LT, LU, LV, MA, MD, MG, MK, MN, MW, MX, MZ, NA, NI, NO, NZ, OM, PG, PH, PL, PT, RO, RU, SC, SD, SE, SG, SK, SL, SY, TJ, TM, TN, TR, TT, TZ, UA, UG, US, UZ, VC, VN, YU, ZA, ZM, ZW.

(22) International Filing Date: 20 July 2004 (20.07.2004)

(25) Filing Language: English

(26) Publication Language: English

(30) Priority Data:
60/488,408 21 July 2003 (21.07.2003) US
60/488,409 21 July 2003 (21.07.2003) US
60/517,073 5 November 2003 (05.11.2003) US
60/517,084 5 November 2003 (05.11.2003) US
60/544,356 17 February 2004 (17.02.2004) US
60/544,357 17 February 2004 (17.02.2004) US
PCT/IL04/000571 27 June 2004 (27.06.2004) IL

(84) Designated States (unless otherwise indicated, for every kind of regional protection available): ARIPO (BW, GH, GM, KE, LS, MW, MZ, NA, SD, SL, SZ, TZ, UG, ZM, ZW), Eurasian (AM, AZ, BY, KG, KZ, MD, RU, TJ, TM), European (AT, BE, BG, CH, CY, CZ, DE, DK, EE, ES, FI, FR, GB, GR, HU, IE, IT, LU, MC, NL, PL, PT, RO, SE, SI, SK, TR), OAPI (BF, BJ, CF, CG, CI, CM, GA, GN, GQ, GW, ML, MR, NE, SN, TD, TG).

(71) Applicant (for all designated States except US): MOLECULAR CYTOMICS LTD. [CY/CY]; P.O. Box 21255, 1505 Nicosia (CY).

Published:
— with international search report
— before the expiration of the time limit for amending the claims and to be republished in the event of receipt of amendments

(72) Inventors; and
(75) Inventors/Applicants (for US only): DEUTSCH, Mordechai [IL/IL]; 73 Moshav Olesh, 42 855 Doar Na Lev-HaSharon (IL). HERZBERG, Max [IL/IL]; Moshav Sitria, P. O. Box 7, 76 834 Emeq Soreq (IL). TIROSH, Reuven [IL/IL]; 20 Ben Gurion Street, 44257 Kfar Saba (IL). DEUTSCH, Assaf [IL/IL]; 12 Moshav Tzofaria, 60 932 Moshav Tzofaria (IL).

(88) Date of publication of the international search report: 14 April 2005

For two-letter codes and other abbreviations, refer to the "Guidance Notes on Codes and Abbreviations" appearing at the beginning of each regular issue of the PCT Gazette.

(54) Title: IMPROVED MULTIWELL PLATE

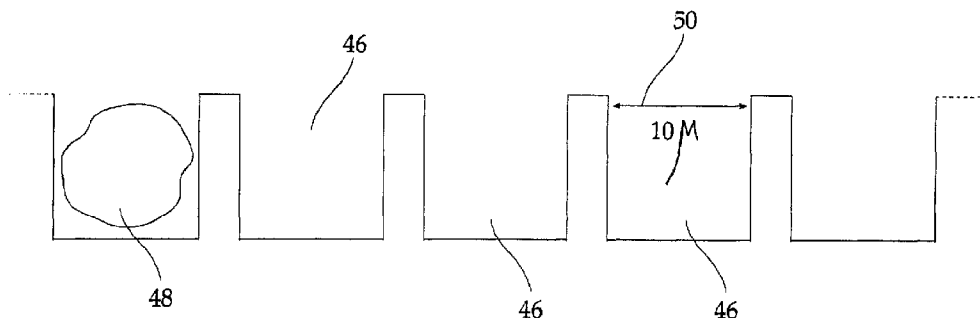

(57) Abstract: A multiwell plate (52) having a plurality of picowells (46) on the bottom of the wells of the plate as well as methods of producing the multiwell plate are provided. Provided is also a method of handling living cells (48) by providing an ordered array of living cells immobilized in a non-fluid matrix, contacting the living cells with a stimulus; and detecting a response to the stimulus. The present invention is also of a method of producing an ordered array of living cells.



WO 2005/007796 A3

INTERNATIONAL SEARCH REPORT

International application No.

PCT/IL04/00661

A. CLASSIFICATION OF SUBJECT MATTER

IPC(7) : C12M 3/00; C12N 5/00
 US CL : 435/395, 305.2

According to International Patent Classification (IPC) or to both national classification and IPC

B. FIELDS SEARCHED

Minimum documentation searched (classification system followed by classification symbols)
 U.S. : 435/30, 395-397, 401, 402, 288.4, 288.5, 293.1, 297.2, 297.5, 305.2, 305.3, 309.1; 359/398

Documentation searched other than minimum documentation to the extent that such documents are included in the fields searched

Electronic data base consulted during the international search (name of data base and, where practicable, search terms used)

C. DOCUMENTS CONSIDERED TO BE RELEVANT

Category *	Citation of document, with indication, where appropriate, of the relevant passages	Relevant to claim No.
X	WO 03/035824 A1 (DEUTSCH et al.) 01 May 2003 (01.05.2003), see entire document.	1-54, 67-80, 88-106, 113-134
Y		55-65, 81, 107-112, 135-185
Y	US 5,627,045 A (BOSHNER et al.) 06 May 1997 (06.05.1997), see entire document.	55-65, 81, 107-112, 135-185
Y	US 4,308,351 A (LEIGHTON et al.) 29 December 1981 (29.12.1981), see entire document.	55-65, 81, 107-112, 135-185
Y	US 2002/0173033 A1 (HAMMERICK et al.) 21 November 2002 (21.11.2002), see entire document.	55-65, 81, 107-112, 135-185

Further documents are listed in the continuation of Box C.

See patent family annex.

* Special categories of cited documents:	"T"
"A" document defining the general state of the art which is not considered to be of particular relevance	later document published after the international filing date or priority date and not in conflict with the application but cited to understand the principle or theory underlying the invention
"E" earlier application or patent published on or after the international filing date	"X" document of particular relevance; the claimed invention cannot be considered novel or cannot be considered to involve an inventive step when the document is taken alone
"L" document which may throw doubts on priority claim(s) or which is cited to establish the publication date of another citation or other special reason (as specified)	"Y" document of particular relevance; the claimed invention cannot be considered to involve an inventive step when the document is combined with one or more other such documents, such combination being obvious to a person skilled in the art
"O" document referring to an oral disclosure, use, exhibition or other means	"&" document member of the same patent family
"P" document published prior to the international filing date but later than the priority date claimed	

Date of the actual completion of the international search

08 February 2005 (08.02.2005)

Date of mailing of the international search report

02 MAR 2005

Name and mailing address of the ISA/US

Mail Stop PCT, Attn: ISA/US
 Commissioner for Patents
 P.O. Box 1450
 Alexandria, Virginia 22313-1450

Facsimile No. (703) 305-3230

Authorized officer

William H. Beisner

Telephone No. 571-272-1700